

# CLARK

## UNIVERSAL HYDRATORK

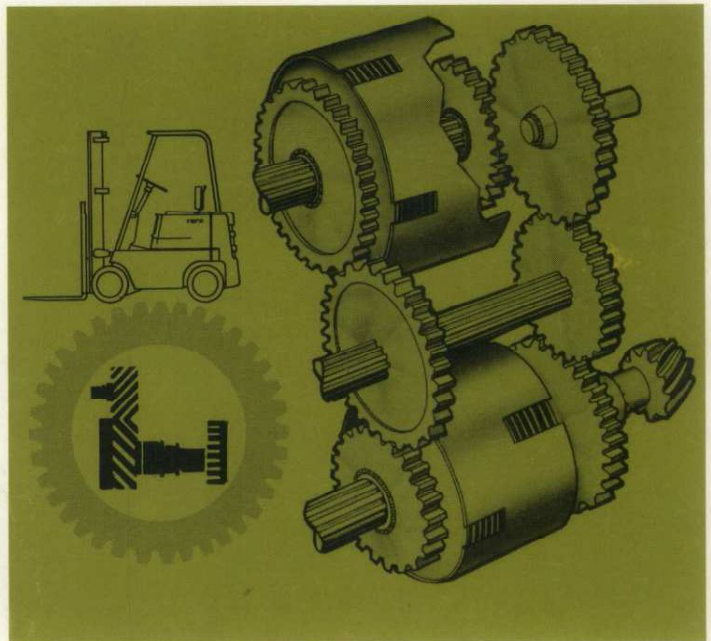

*How it works*

*How to trouble shoot it*

**CLARK** Industrial Truck  
Division

Clark Equipment Company  
Marketing Training & Communications Dept.  
525 North 24th Street  
Battle Creek, Michigan 49016

# TABLE OF CONTENTS

	Page
INTRODUCTION TO UNIVERSAL HYDRATORK . . . . .	1
Part 1 . . . Torque Converter. . . . .	2
Part 2 . . . Transmission Mechanical Components. . . . .	6
Part 3 . . . Transmission Hydraulic System . . . . .	12
Part 4 . . . Trouble Shooting. . . . .	22
APPENDIX I . . . Disassembly and Assembly Tips . . . . .	33
APPENDIX II . . . Complete Hydraulic Circuits . . . . .	39

# Introduction to Universal Hydratorck

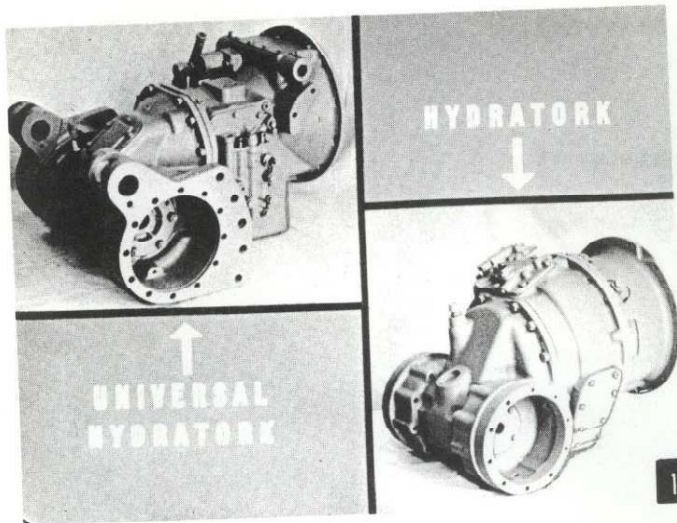

1. Generally speaking, the new Universal Hydratorck is not too much different from the Hydratorck. The main difference between them is that the Universal has two speed ranges, — high and low — while the Hydratorck has only one speed range.

## NOTE

It is possible for customers to order the Universal Hydratorck with only one speed range. In this case, the high-low drum is replaced by gears which provide only one gear ratio.

2. What this means is that the Universal has four power-shifted packs — forward and reverse, and high and low — while the Hydratorck has only two power-shifted packs — forward and reverse.

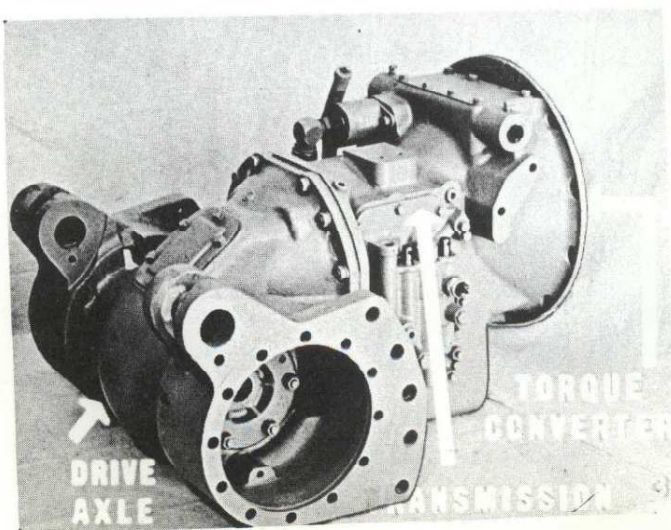
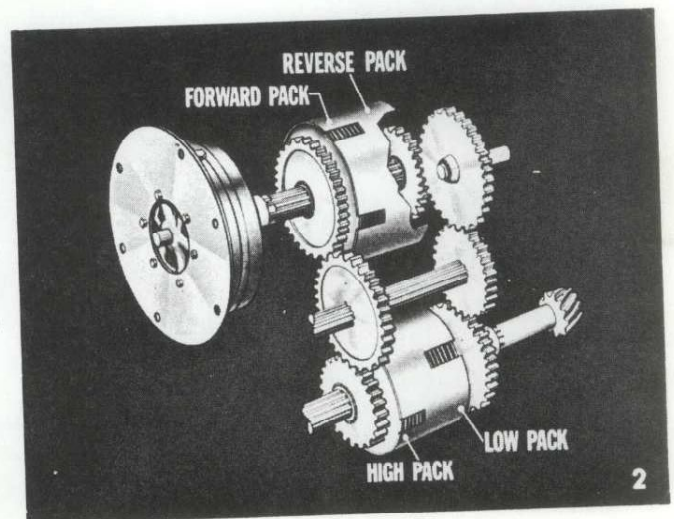

3. The Universal Hydratorck drive consists of three basic units — torque converter, transmission and drive axle. Though the drive axle is part of the drive train, it is a complete subject in itself, and, therefore, is not included in this presentation.

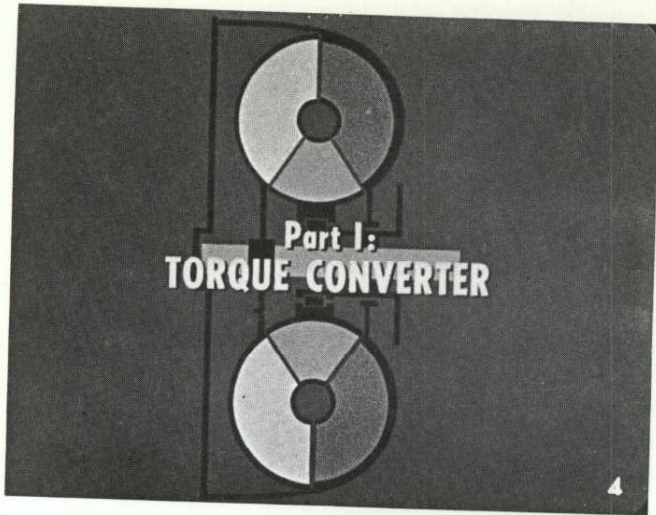

4. Now — let's get into the torque converter. This fluid-operated device takes the place of a conventional clutch and it can multiply torque. Though it is not repairable, we will cover its operation in detail so that you will be equipped to detect converter problems.

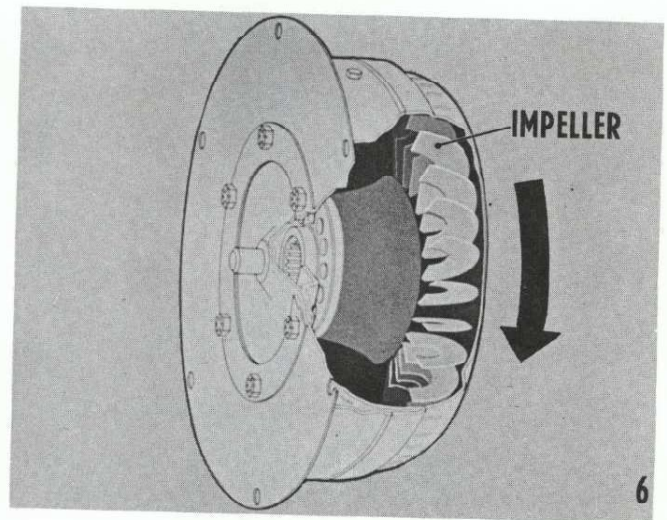
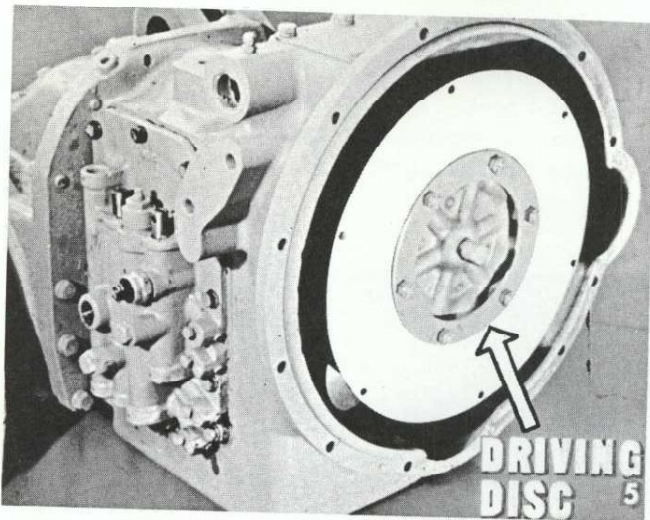

5. The torque converter is driven by the engine through its driving disc, which is bolted to the engine flywheel. The converter, in turn, drives the mechanical parts — the pump, shafts, gears and drums — of the transmission.

6. The torque converter consists of three units — an impeller, or pump, which is driven by the engine ...

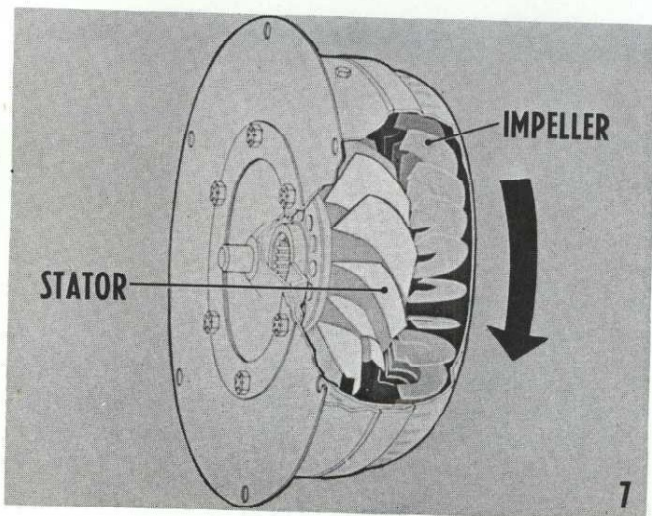

7. . . . a stator which can rotate only in the direction of impeller rotation . . . because it is mounted on a one-way sprag clutch . . .

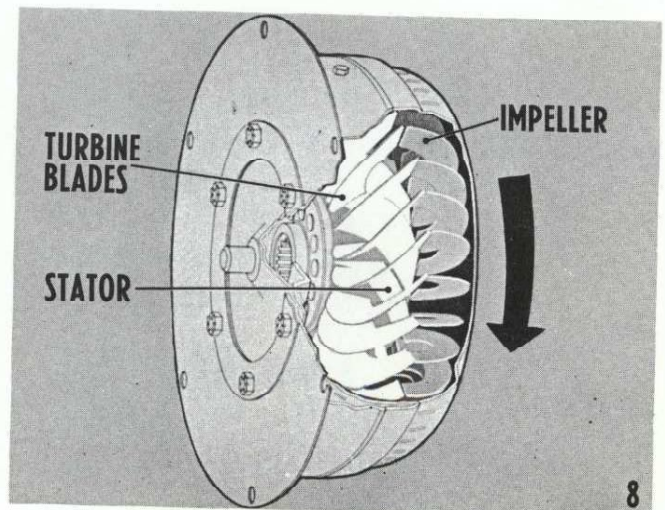

8. . . . and a turbine which is driven by fluid thrown from the impeller.

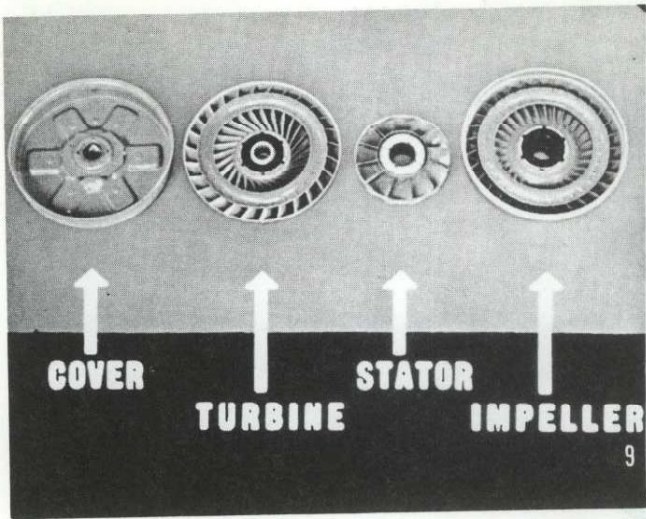

9. The impeller, and the cover welded to it form an outer housing. The turbine and stator are enclosed in this housing, which is completely filled with fluid. Both the impeller and turbine have blades which curve in opposite directions.

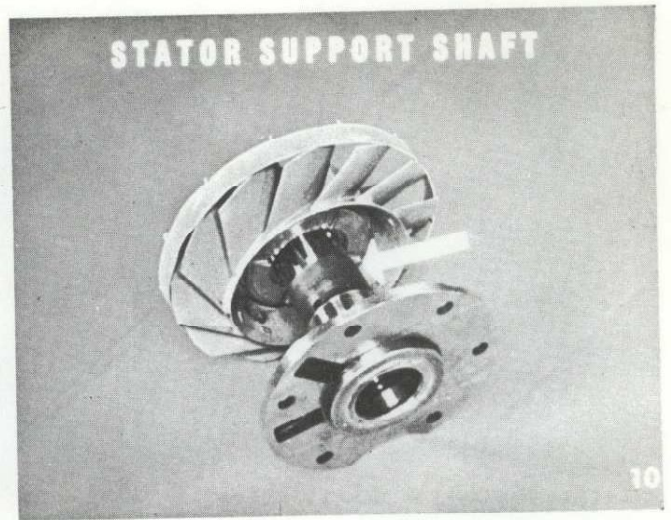

10. The stator and its one-way sprag clutch are mounted on a stationary stator support shaft which is bolted to the transmission case.

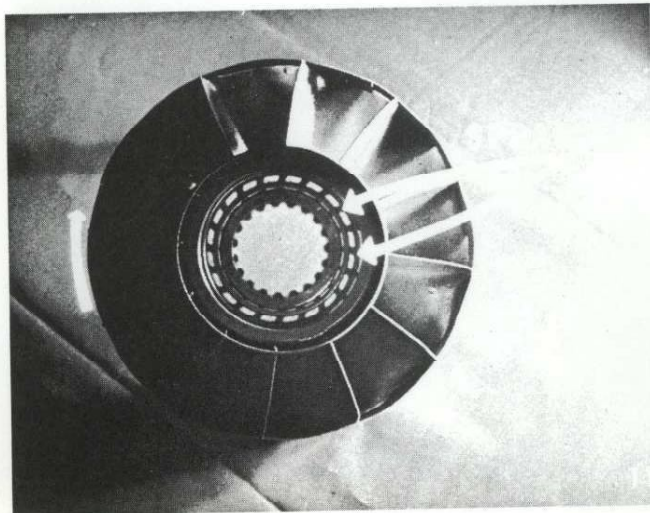

11. The clutch sprags - which are tiny wedges - allow the stator to rotate only in the direction that the impeller rotates. When oil is so directed that it tries to turn the stator opposite impeller rotation - the wedges lock the stator to the stator support shaft and prevent backward rotation of the stator.

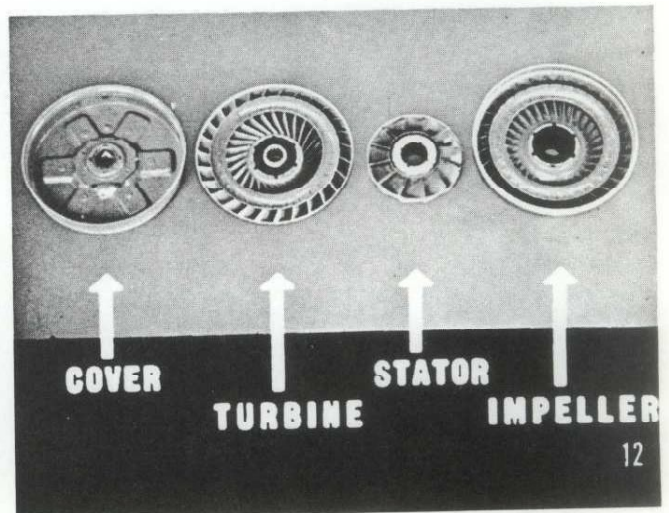

12. To understand how the converter multiplies torque, it is necessary to trace the flow of fluid from impeller to turbine, turbine to stator, and stator to impeller - from the time the engine is started until the converter no longer multiplies torque.

Part 1 - Torque Converter

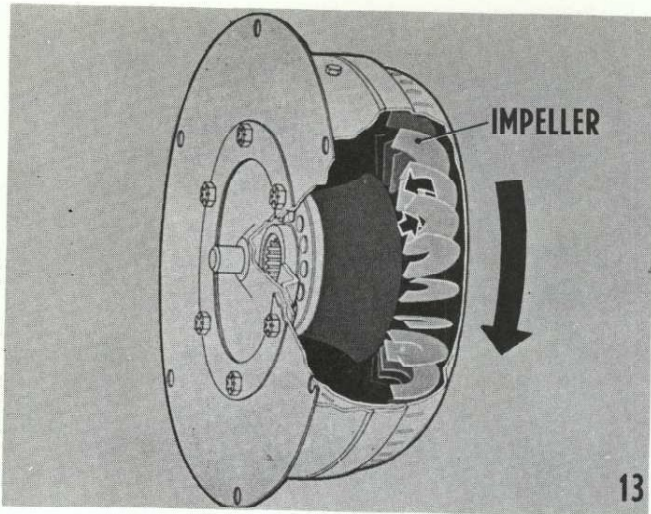

13. First, fluid is hurled, at high speed, from the impeller. The fluid is directed into . . .

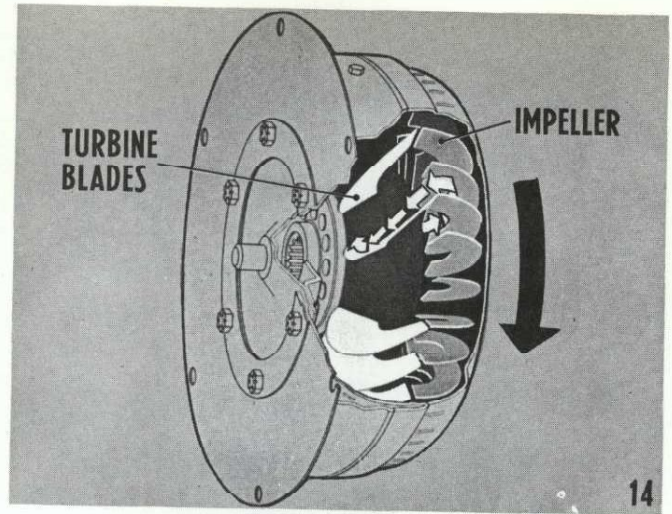

14. . . the turbine blades . . . and exerts force on them. Then, the fluid flows down through the turbine, and is thrown from it - at high speed and in a direction opposite impeller rotation.

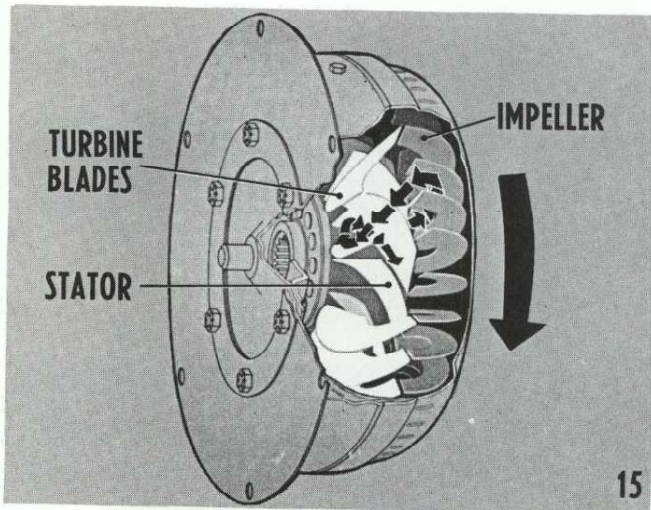

15. The fluid then enters the stator, and tries to turn it opposite impeller rotation - an action prevented by the one way clutch. Since the stator cannot rotate opposite impeller rotation, the fluid bounces off the front faces of the curved stator blades, changes direction, and races out of the stator in the same direction the impeller is turning.

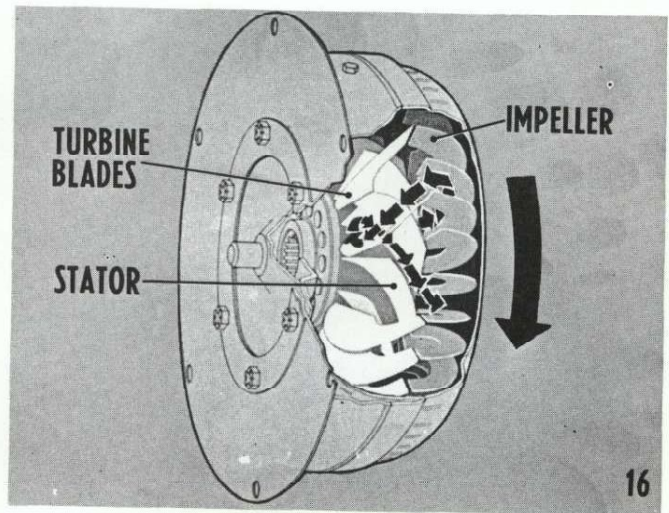

16. The fluid, still traveling at high speed, re-enters the impeller. The kinetic energy\* of the fast moving fluid is added to engine power, and the fluid is hurled from impeller to turbine with increased velocity and energy - thus multiplying torque.

\*NOTE

Energy created by motion.

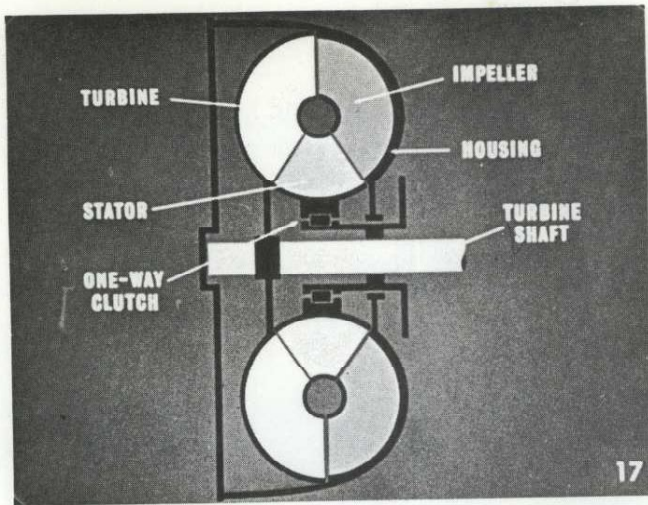

17. The torque converter produces a maximum torque multiplication of slightly more than 2 to one when the impeller is turning and the turbine is not. This is known as the stall point of the converter. When enough torque is developed by the engine and converter, the turbine begins to rotate, turning the turbine or input shaft ... which drives the transmission components.

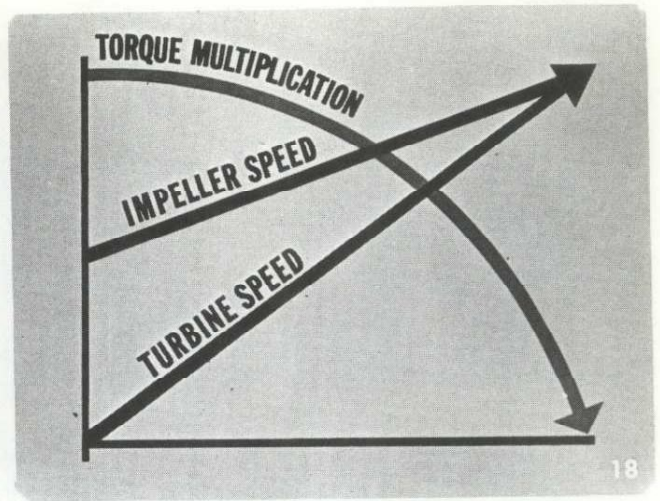

18. Torque multiplication gradually tapers off as turbine speed approaches impeller speed – and becomes 1 to 1 when the turbine rotates at about 9/10ths impeller speed. At this point, the converter no longer multiplies torque.

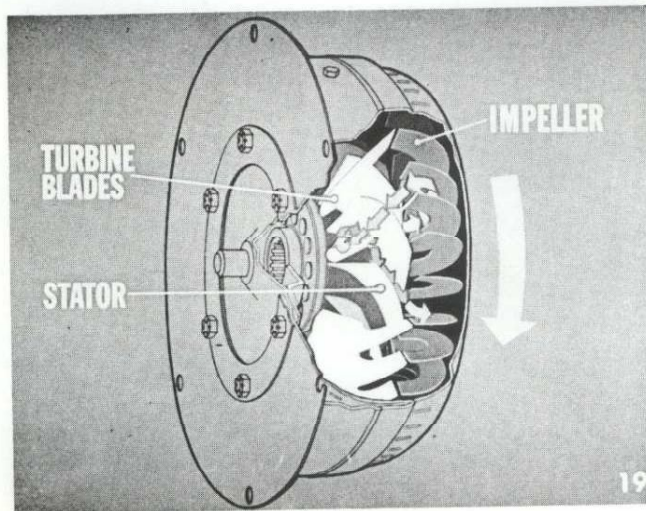

19. When the turbine rotates faster than 9/10ths impeller speed, the fluid leaving the turbine hits the back faces of the stator blades. The one-way clutch now permits the stator to turn with the impeller and turbine. At this point, the converter is an efficient fluid coupling and remains one as long as turbine speed is greater than 9/10ths impeller speed.

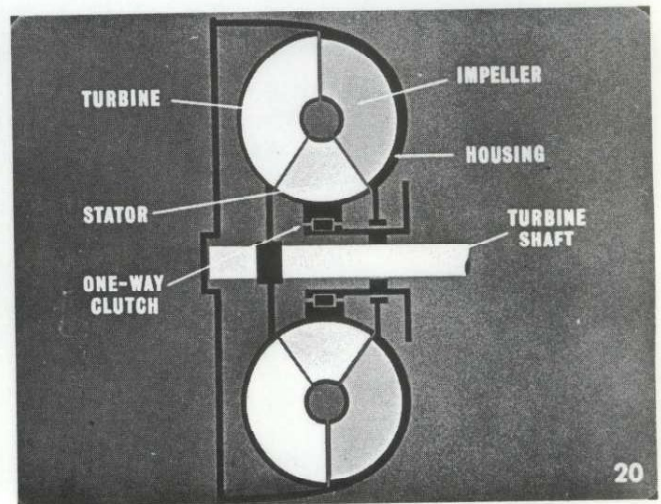

20. From the foregoing, it can be seen that, from the time the turbine is not rotating to the point where the converter becomes a fluid coupling, the converter acts as an infinitely variable, fluid-operated transmission. And that, above the "coupling point", it acts as an efficient fluid coupling.



21

21. Now, let's take a look at the transmission mechanical components and power flow through the unit ... which is hydraulically operated and has all gears in constant mesh.

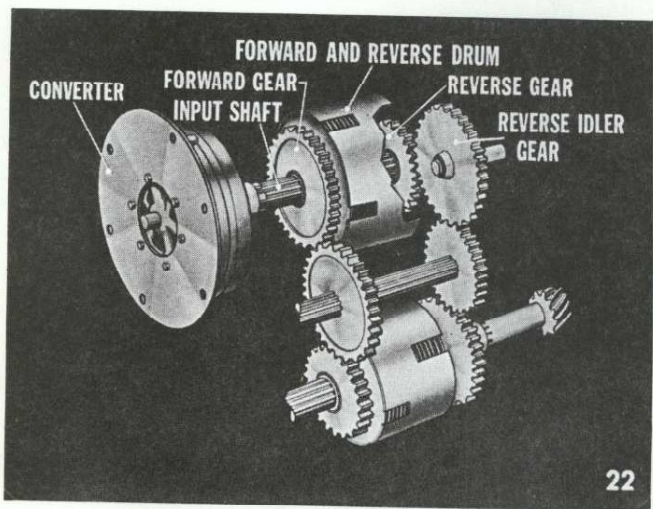

22

22. The primary mechanical components of the transmission are the input shaft, coming out of the converter, the forward gear, the forward and reverse drum, the reverse gear, the reverse idler gear ...

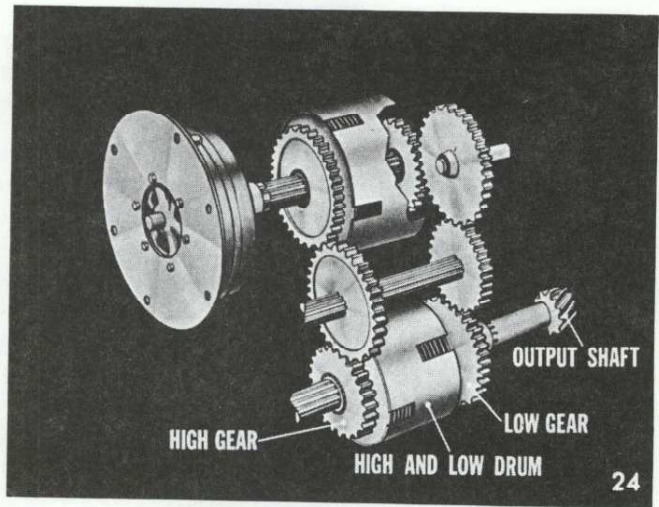

24

24. ... the high gear, the high and low drum, the low gear, and the output shaft.

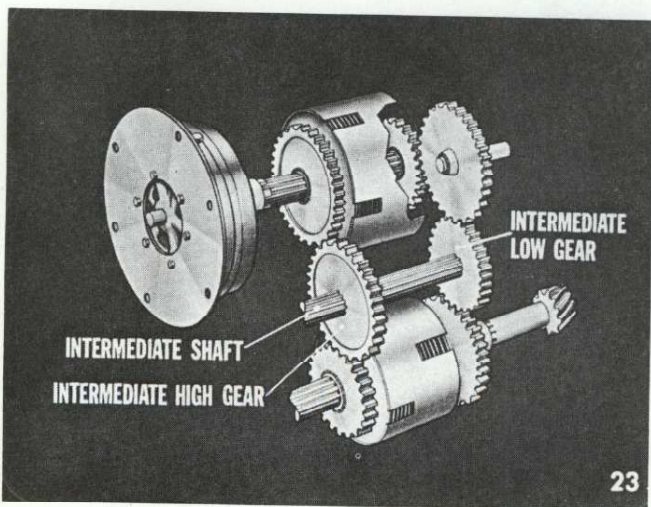

23

23. ... the intermediate shaft, the intermediate high gear, the intermediate low gear ...

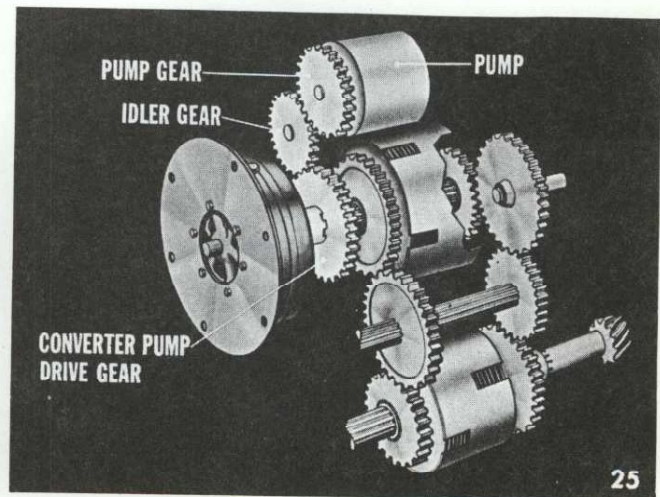

25

25. Finally, we have the transmission charging pump which supplies the hydraulic fluid required to operate the transmission. The pump is driven directly by the converter support hub, and operates whenever the engine is running.

**NOTE**

Charging pumps, installed in earlier Universal Hydratorks (through lot 489), are driven off cranks shafts.

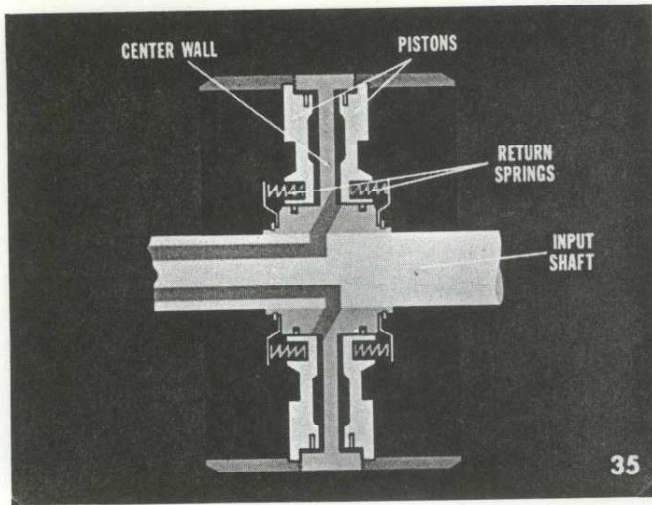

35. To provide complete detail of a drum assembly, we'll build up the forward and reverse drum in cross section. The drum has a center wall or partition which splines to the input shaft. Then there are the forward and reverse pistons – one on each side of the wall ... and the piston return springs.

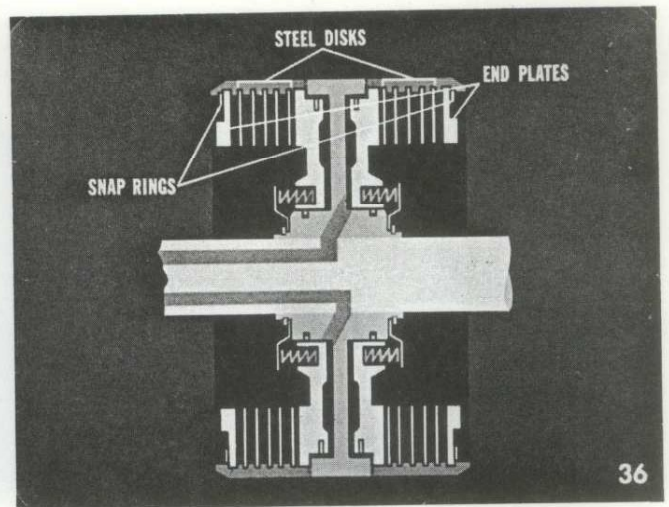

36. Next ... there are the steel discs and the two end plates. These ... along with the pistons ... are always engaged in the slots in the drum, and always turn with the drum. The end plates are retained by snap rings.

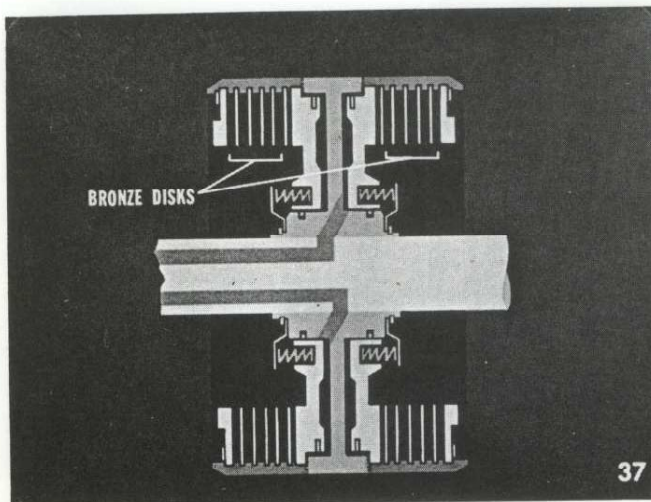

37. Then, we have the bronze disks ... which are not engaged to the drum but which ...

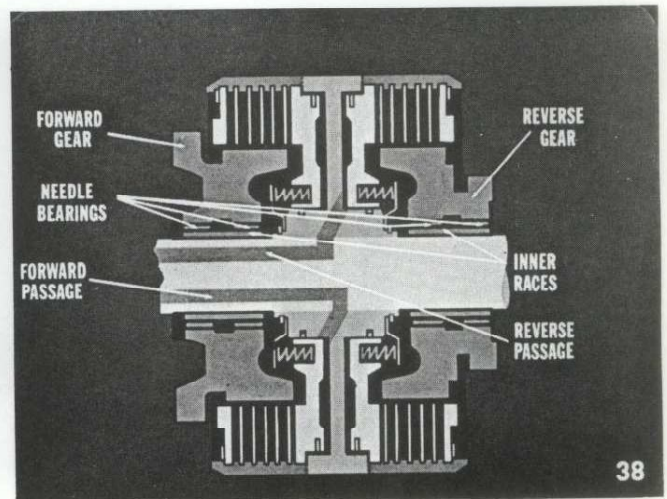

38. ... are splined to the forward and reverse gears. Both of these gears – as shown here – contain needle bearings which ride on the inner races which are splined to the input shaft. The input shaft has two drilled passages which carry fluid to the packs to provide hydraulic pressure to move the pistons.

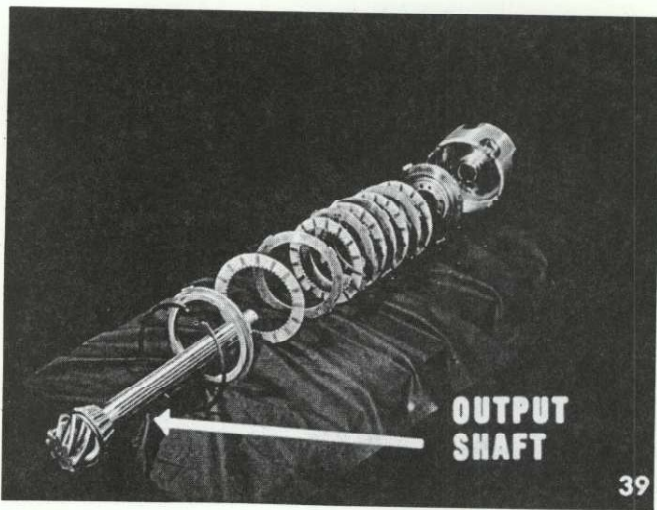

39. The high-low drum ... which is completely interchangeable with the forward-reverse drum ... also contains two packs identical to those in the forward and reverse drum. The gears in the high-low drum, drive the bronze discs, the steel discs drive the drum, the drum drives the output shaft.

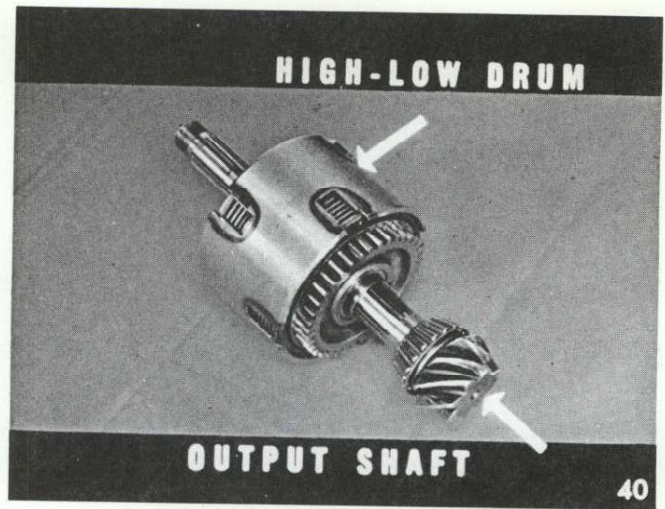

40. The high-low drum is splined to the output shaft ... and one of its two packs – either high or low – is always engaged. The high and low gears are identical to the forward and reverse gears. However, their positions are reversed in the drums.

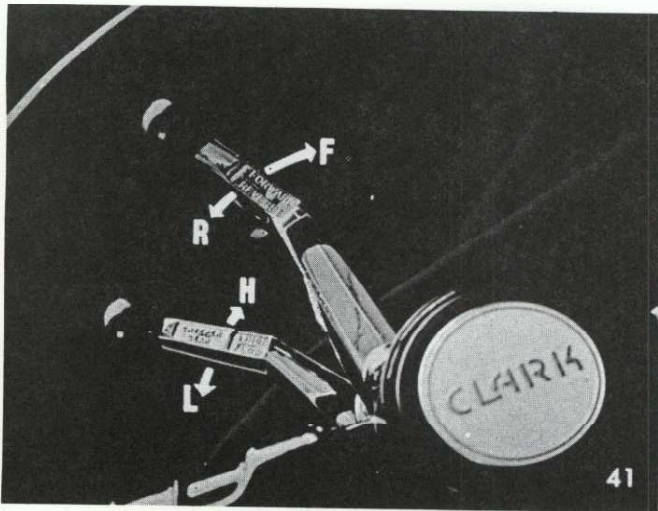

41. Now, let's trace the flow of power through the transmission with selector levers in neutral, forward in high, forward in low, reverse in high, and reverse in low.

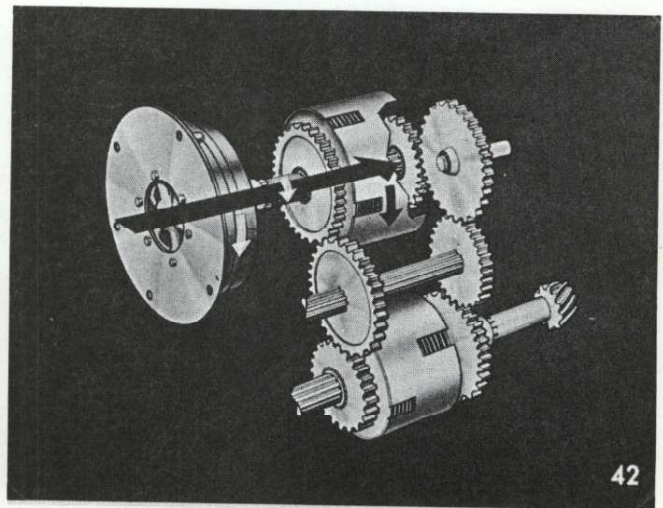

42. With the forward or reverse selector lever in neutral both forward and reverse packs are disengaged and no power can be transmitted through the intermediate gears and high-low drum to the pinion or output shaft.