

Service Manual

SM 638

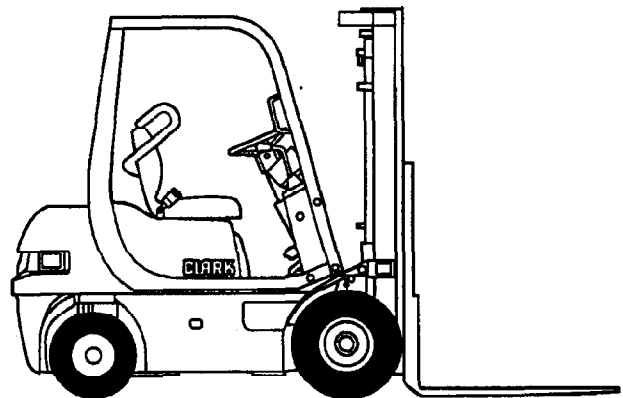

CMP 15/18/20/25/30

Revision 1. October, 1998



CLARK Technical
Publications
Lexington, KY
40508

Contents

Contents are listed by Group number and name followed by Section number and name:

- | | | | |
|-----------|---|--------------|--|
| SA | SAFE MAINTENANCE <ol style="list-style-type: none">1. Safety2. Lifting, Jacking, and Blocking3. Towing | 16 | WHEELS AND TIRES <ol style="list-style-type: none">1. Specifications and Description2. Cushion Wheels and Tires3. Pneumatic Wheels and Tires |
| PS | PERIODIC SERVICE <ol style="list-style-type: none">1. Maintenance Schedules2. Planned Maintenance3. PM Inspection Form | 23 | BRAKE SYSTEM <ol style="list-style-type: none">1. Specifications2. Service Brake3. Parking Brake |
| 00 | ENGINE <ol style="list-style-type: none">1. Specifications and Description2. Troubleshooting3. Engine Oil4. Tune-Up5. RPM, Vacuum, and Stall Checks6. Compression Checks7. Removal and Replacement8. Overhaul | 25/26 | STEER SYSTEM <ol style="list-style-type: none">1. Specifications and Description2. Troubleshooting3. Steering System Pressure Check4. Steering System Removals & Installations5. Steering Unit Overhaul6. Priority Valve Overhaul7. Steer Cylinder Overhaul |
| 01 | COOLING SYSTEM <ol style="list-style-type: none">1. Specifications and Description2. Troubleshooting | 29/30 | HYDRAULIC SYSTEM <ol style="list-style-type: none">1. Specifications and Description2. Troubleshooting3. Hydraulic Pump Overhaul4. Control Valve Overhaul |
| 02 | FUEL SYSTEM <ol style="list-style-type: none">1. LPG Fuel System2. Gasoline Fuel System | 34 | UPRIGHTS <ol style="list-style-type: none">1. Specifications and Description2. Upright Checks and Adjustments3. Lift Chain Service4. Removals and Replacements5. Lift and Tilt Cylinder Overhaul |
| 06 | TRANSAXLE <ol style="list-style-type: none">1. Specifications and Description2. Checks and Troubleshooting3. Removal and Replacement3. Overhaul | 38 | COUNTERWEIGHT <ol style="list-style-type: none">1. Specifications2. Inspection3. Removal and Replacement |
| 12 | IGNITION SYSTEM <ol style="list-style-type: none">1. Specifications and Description2. Troubleshooting3. Ignition Timing4. Distributor Overhaul | 40 | SPECIFICATIONS <ol style="list-style-type: none">1. Specifications |
| 14 | ELECTRICAL <ol style="list-style-type: none">1. Circuit Diagram2. Starter3. Alternator4. Instrument Pod | | |

➔J➔ Oil Pump Sprocket Installation

1. Insert a Phillips screwdriver [shank diameter 8 mm (0.31 in.)] through the plug hole on the left side of the cylinder block to lock the left silent shaft.
2. Install the oil pump sprocket.
3. Apply an appropriate amount of engine oil to the bearing surface of the nut.
4. Tighten the nuts to the specified torque.

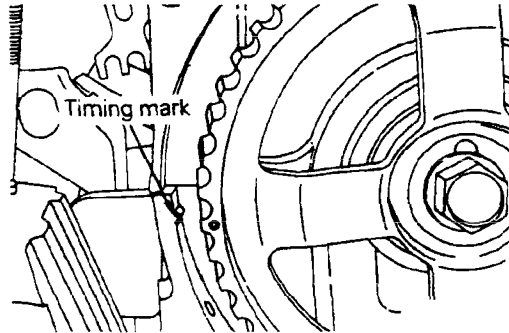
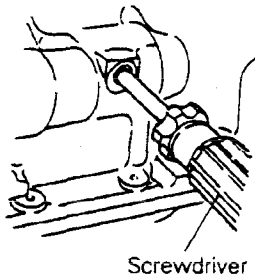

3. Align the timing mark on the crankshaft sprocket with that on the front case.

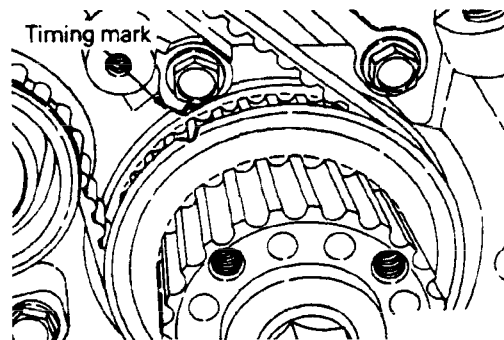

➔K➔ Tensioner Installation

1. Hook the tensioner spring ends to the water pump body projection and tensioner bracket.
2. Move the tensioner fully toward the water pump and tighten the bolt and tensioner spacer.

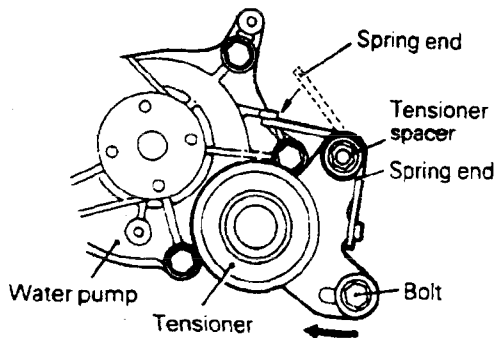

4. Align the timing mark on the oil pump with its mating mark.

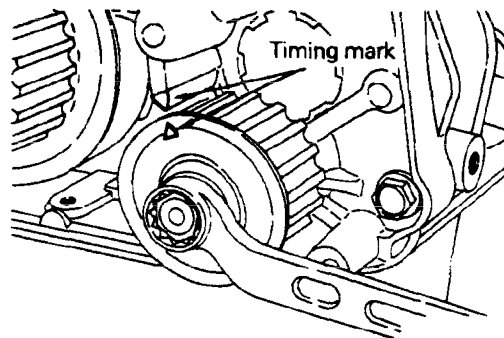

➔N➔ Timing Belt Installation

1. Check that the timing belt tensioner and spring have been installed in position. (See ➔K➔)
2. Align the timing mark on the camshaft sprocket with that on the cylinder head.

- With the plug on the cylinder block removed, insert a Phillips screwdriver [shank diameter 8 mm (0.31 in.)] through the hole.

If it can be inserted as deep as 60 mm (2.4 in.) or more, the timing marks are correctly aligned. If the inserted depth is only 20-25 mm (0.8-1.0 in.), turn the oil pump sprocket one turn and realign the timing marks. Then check to ensure that the screwdriver can be inserted 60 mm (2.4 in.) or more. Keep the screwdriver inserted until installation of the timing belt is finished.

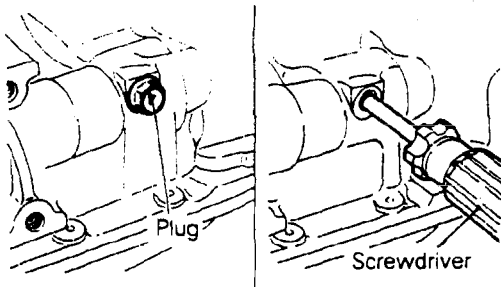

- Install the timing belt on the crankshaft sprocket, oil pump sprocket and camshaft sprocket in that order. There should be no slack on the tension side.
- Loosen the tensioner mounting bolt and tensioner spacer.

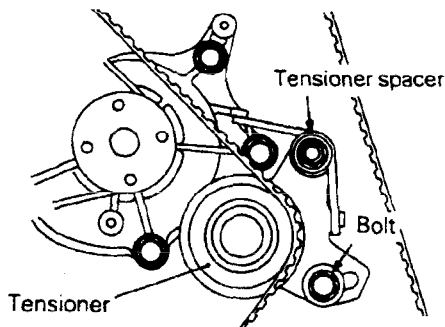

- Turn the crankshaft clockwise by two teeth of the camshaft sprocket (or crankshaft sprocket).

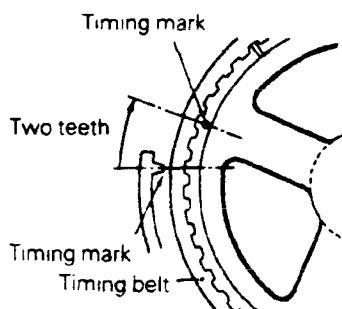

- Apply force to the tensioner in the direction shown by arrow [B] to make the belt engage completely with each sprocket.

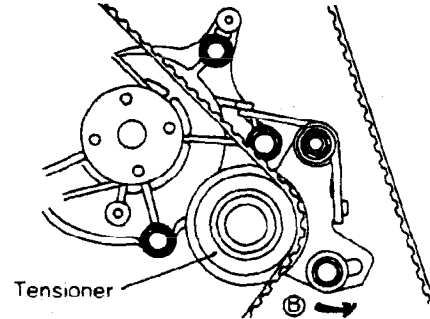

- Tighten the tensioner attaching bolt then tighten the tensioner spacer.

⚠ CAUTION

If the tensioner spacer is tightened first, the tensioner turns as the tensioner spacer is tightened, resulting in an excessive belt tension.

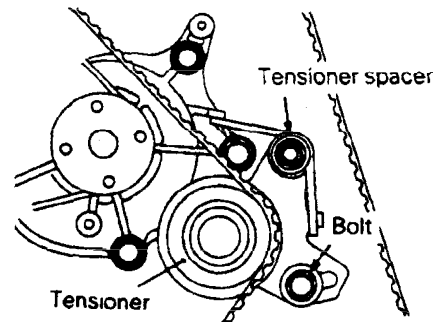

- Hold the center of the tension side span of the timing belt (between the camshaft and oil pump sprockets) as shown. Then, make sure that the clearance between the belt back surface and cover meets the standard value.

Standard value: 14 mm (0.55 in.)

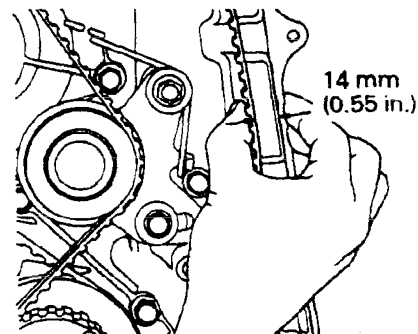

Exhaust Manifold and Water Pump

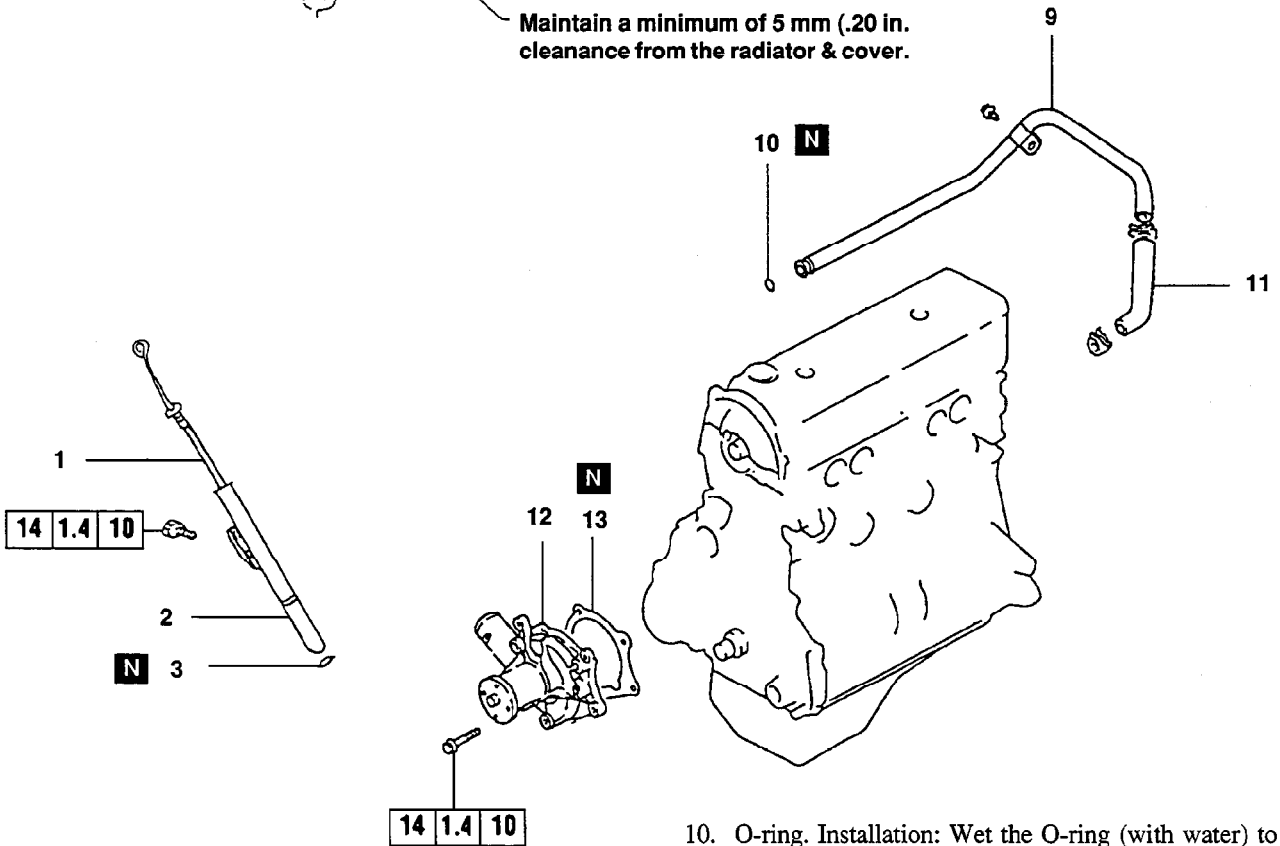
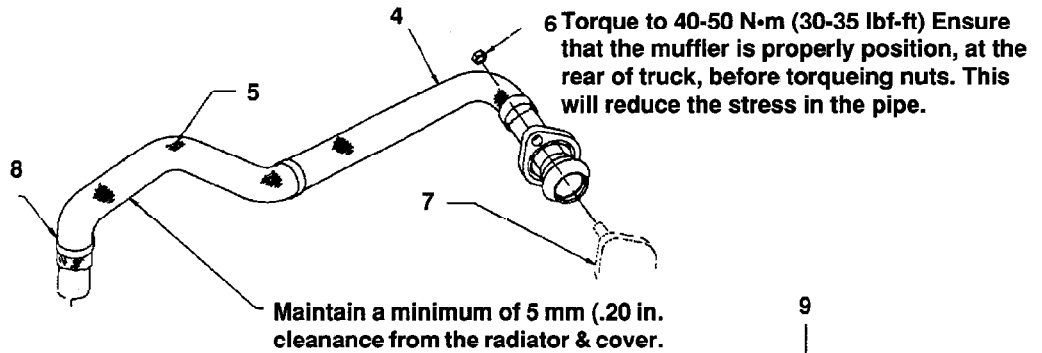

Removal Steps

1. Oil dipstick
2. Oil dipstick tube
3. O-ring
4. Heat protector
5. Heat protector
6. Nut
7. Exhaust manifold
8. Hose clamp
9. Water inlet pipe

10. O-ring. Installation: Wet the O-ring (with water) to facilitate assembly. Keep the O-ring free of oil or grease.

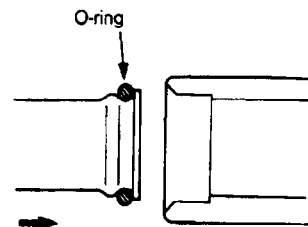

11. Water hose
12. Water pump
13. Gasket

Rocker Arms and Camshaft

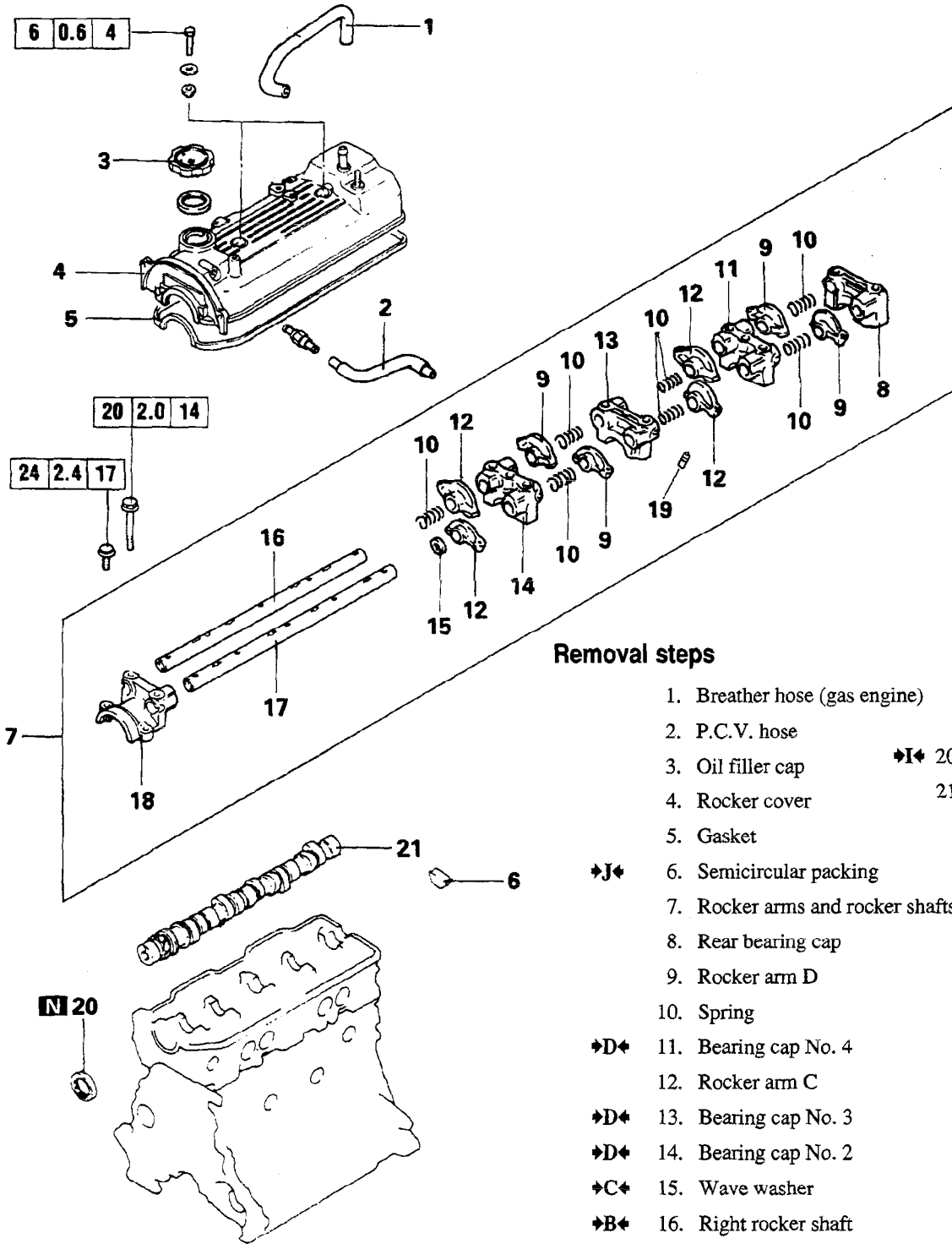

Removal steps

1. Breather hose (gas engine)
2. P.C.V. hose
3. Oil filler cap
4. Rocker cover
5. Gasket
6. Semicircular packing
7. Rocker arms and rocker shafts
8. Rear bearing cap
9. Rocker arm D
10. Spring
11. Bearing cap No. 4
12. Rocker arm C
13. Bearing cap No. 3
14. Bearing cap No. 2
15. Wave washer
16. Right rocker shaft
17. Left rocker shaft
18. Front bearing cap
19. Lash Adjuster
20. Oil seal
21. Camshaft

Removal Service Point

Before removing rocker arms and shafts assembly, install the special tool as illustrated to prevent the lash adjusters from dropping.

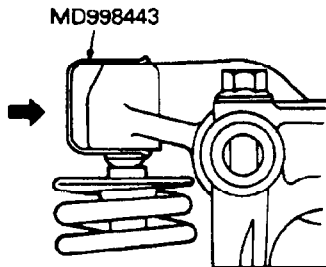

Inspection

Camshaft

Measure the cam height, using the following values:

Identification mark	Standard value mm (in)	Limit mm (in)
Intake	41.62 (1.64)	41.12 (1.62)
Exhaust	41.62 (1.64)	41.12 (1.62)

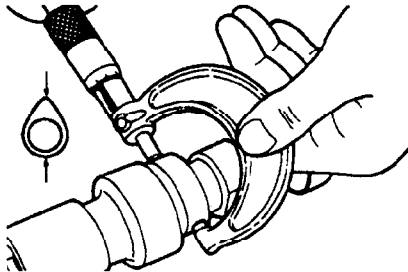

Rocker Arm

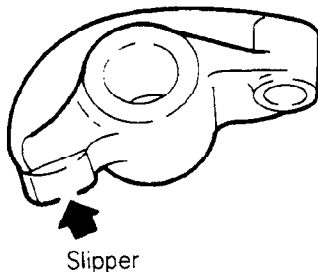

Check the slipper surface. If any dents, damage, or seizure is evident, replace the rocker arm.

Lash Adjuster Leak Down Test

⚠ CAUTION

The lash adjuster is a precision part. Keep it free from dust and other foreign matter.

Do not disassemble lash adjusters.

When cleaning lash adjusters, use clean diesel fuel only.

1. Immerse the lash adjuster in clean diesel fuel.

2. While lightly pushing down the inner steel ball using the special tool, Air Bleed Wire, move the plunger up and down four or five times to bleed air. Use of the retainer (special tool) helps facilitate the air bleeding of the rocker arm mounted type lash adjuster.
3. Remove the wire and press the plunger. If the plunger is hard to be pushed in, the lash adjuster is normal. If the plunger can be pushed in all the way readily, bleed the lash adjuster again and test again. If the plunger is still loose, replace the lash adjuster.

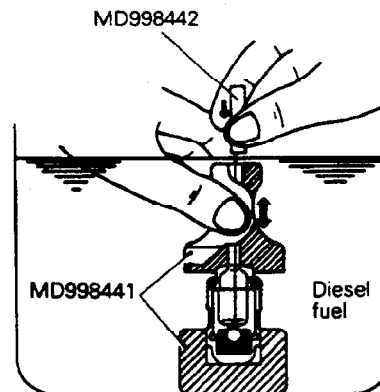

⚠ CAUTION

Upon completion of air bleeding, hold the lash adjuster upright to prevent inside diesel fuel from spilling and keep it free from dust and other foreign matter.

4. After air bleeding, set the lash adjuster on the special tool (Leak down tester MD998440).
5. After the plunger has gone down somewhat (0.2 - 0.5 mm), measure the time taken for it to go down 1 mm. Replace if the measured time is not 5-20 seconds/mm.

Installation Service Points

➔B➔ Rocker Shaft Installation

Insert the rocker shafts into the front bearing cap so that the notches on the shafts face up, and insert the installation bolts without tightening them.

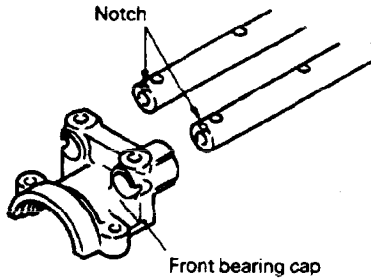

➔C➔ Wave Washer Installation

Install the wave washer in correct direction as shown.

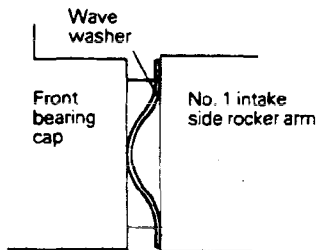

➔F➔ Lash Adjuster Installation

1. Immerse the lash adjuster in clean diesel fuel.
2. Using the special tool (air bleed wire), move the plunger up and down 4 or 5 times while pushing down lightly on the check ball in order to bleed out the air.

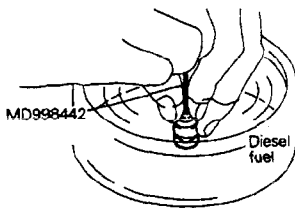

3. Insert the lash adjuster to the rocker arm, being careful not to spill the diesel fuel. Then use the special tool to prevent the adjuster from falling while installing it.

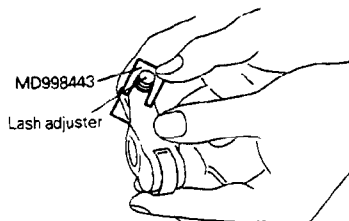

➔G➔ Rocker Shaft Spring, Rocker Arm and Rocker Shaft Installation

1. Temporarily tighten the rocker shaft on the inlet valve side with the bolt so that all rocker arms do not push the valves.
2. Fit the rocker shaft spring from the above and position it so that it is right angles to the spark plug guide.

NOTE

Install the rocker shaft springs before installation of the exhaust side rocker arms and shaft.

3. Remove the special tool used to hold the lash adjuster.
4. Make sure that the notch in the rocker shaft is directed as shown in the illustration.

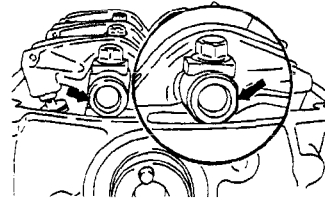

➔I➔ Camshaft Oil Seal Installation

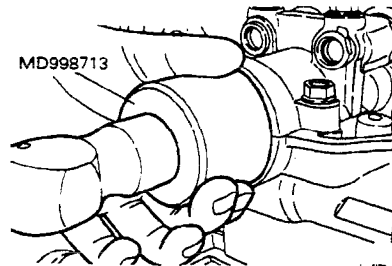

➔J➔ Semi-Circular Packing Installation

Specified sealant:

Threebond 1212D or equivalent

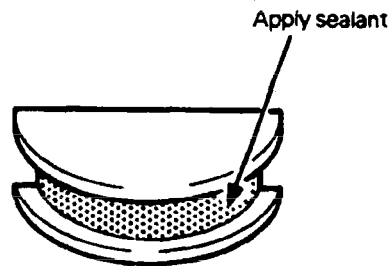

Cylinder Head and Valves

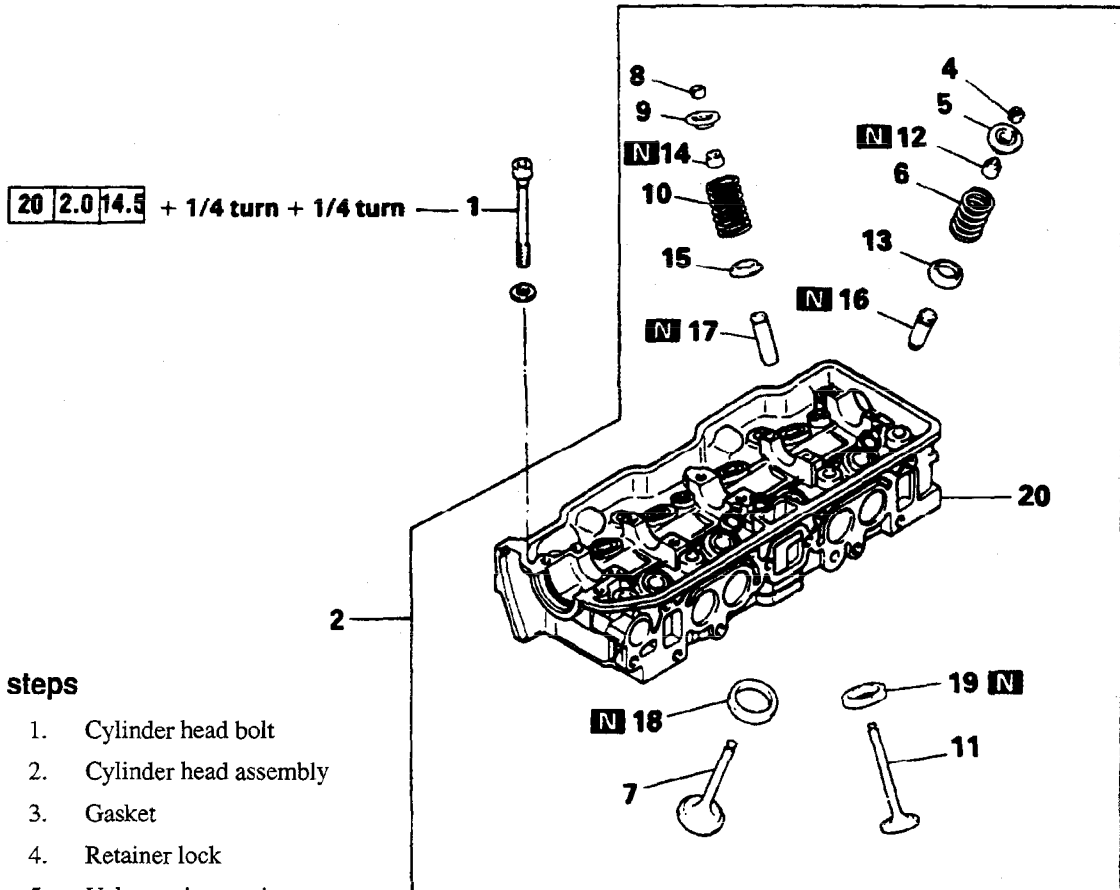

Removal steps

- ↔A↔ ↔D↔ 1. Cylinder head bolt
- 2. Cylinder head assembly
- 3. Gasket
- ↔B↔ ↔C↔ 4. Retainer lock
- 5. Valve spring retainer
- ↔B↔ 6. Valve spring
- ↔B↔ ↔C↔ 7. Intake valve
- 8. Retainer lock
- 9. Valve spring retainer
- ↔B↔ 10. Valve spring
- ↔C↔ ↔A↔ 11. Exhaust valve
- 12. Valve stem seal
- ↔C↔ ↔A↔ 13. Valve spring seat
- 14. Valve stem seal
- 15. Valve spring seat
- 16. Intake valve guide
- 17. Exhaust valve guide
- 18. Intake valve seat
- 19. Exhaust valve seat
- 20. Cylinder head

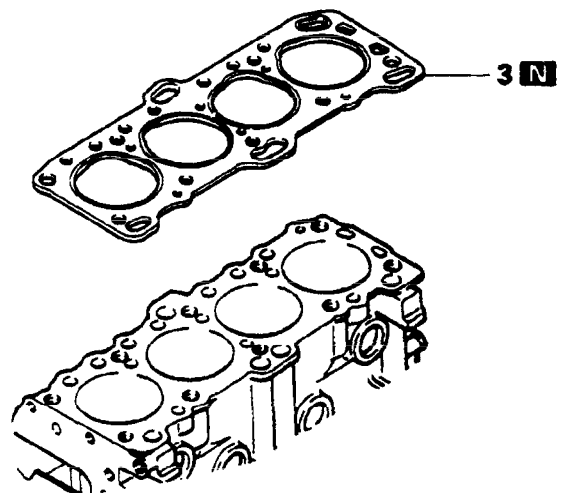

Removal Service Points

Precaution for Removed Parts

Keep removed parts in order according to the cylinder number and intake/exhaust.

◊A◊ Cylinder Head Bolt Removal

Using a 12 mm - 12 point socket wrench, loosen the cylinder head bolts. Loosen evenly, little by little.

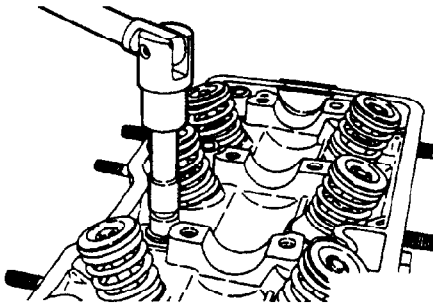

◊B◊ Retainer Lock Removal

Store removed valves, springs and other parts, tagged to indicate their cylinder No. and location for reassembly.

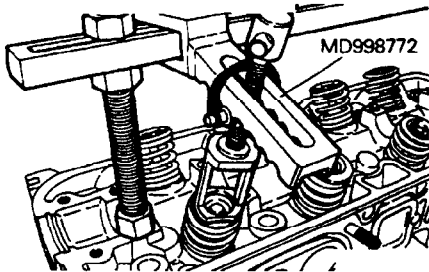

◊C◊ Valve Stem Seal Removal

Do not reuse removed valve stem seal.

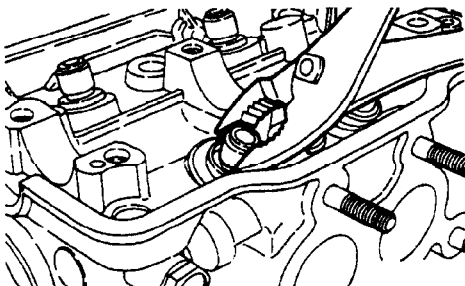

Inspection

Cylinder Head

1. Check the cylinder head for water leaks, gas leaks, damage or cracks before cleaning.
2. Thoroughly remove oil, water scale, sealant, carbon deposits, etc. After the oil passages have been cleaned, blow air to make sure they are clear.

3. Check the cylinder head gasket surface for flatness by using a straightedge and feeler gauge.

Standard value: 0.03 mm (0.0020 in.)

Limit: 0.2 mm (0.008 in.)

Grinding limit: 0.2 mm (0.008 in.)

Cylinder head height (when new):

89.9 - 90.1 mm (3.539 in. - 3.547 in.)

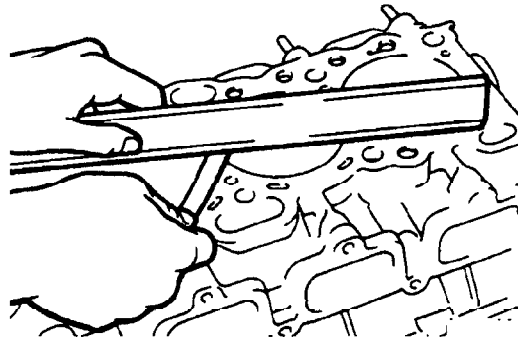

4. If the flatness limit is exceeded, correct to meet the specifications.