

**OH-420  
EC500 355  
36/48 Volt**

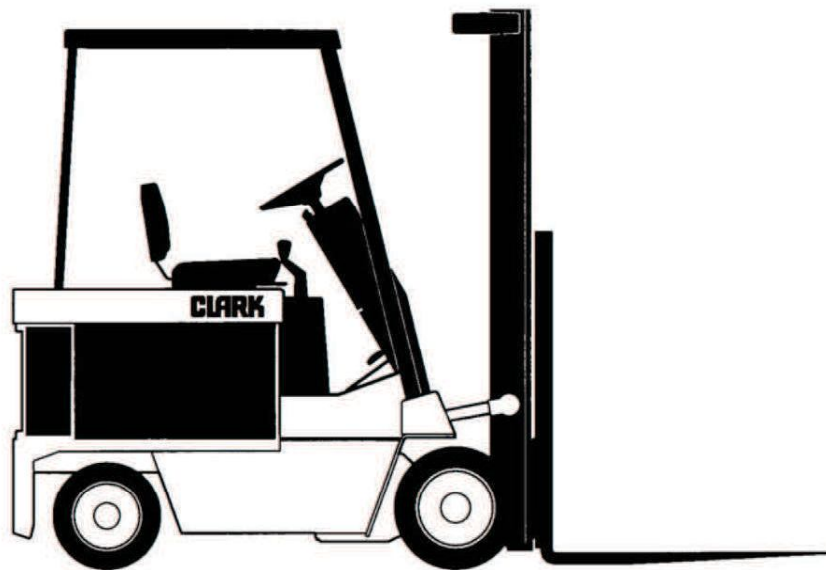

**CLARK** Technical  
Publications  
Lexington, KY  
40508

Copyrighted Material  
Intended for CLARK dealers only  
Do not sell or distribute

## T A B L E O F C O N T E N T S

GROUP	SECTION	PAGE		
16	1	1 - 5	PMA-321	Electric Motor Maintenance
16	5	1 - 13	PMA-340	Electric Motor Remove & Repair
16	6	1 - 3	PMA-340	E.M. Brake Drum Removal
16	12	1 - 9	OH-337	Drive Motor Overhaul
16	15	1 - 9	OH-384	Lift Pump Motor Overhaul
16	17	1 - 9	OH-420	Pump Motor Overhaul
19	3	1 - 27	OH-377	Identification of Filters
19	36	1 - 17	PMA-418	EV-1 Component Identification
19	37	1 - 23	PMA-418	Checking EV-1 SCR Components
20	5	1 - 10	OH-369	Axle End Overhaul
20	7	1 - 13	OH-377	Axle Adaptor Type Differential
23	2	1 - 5	OH-224	Brake Master Cylinder
23	9	1 - 9	OH-337	Overhaul for Brakes With Auto/Adj
23	10	1 - 7	OH-337	Wheel Cylinder Overhaul
26	3	1 - 5	OH-336	Power Steering Pump Overhaul
26	6	1 - 18	OH-377	Power Steering Gear SSG
26	12	1 - 5	OH-420	Power Steering Cylinder Overhaul
29	4	1 - 5	OH-336	Hydraulic Pump Overhaul (Hydreco)
29	10	1 - 7	OH-393	Hydraulic Pump Overhaul (S-15, S-20)
30	2	1 - 14	OH-332	Hydraulic Valve Overhaul
30	7	1 - 8	OH-377	Hydraulic Control Valve
32	5	1 - 9	OH-334	Tilt Cylinder Overhaul (4" Barrel, 1-1/2" Rod)

TO UP-END TRUCK USING TWO CHAIN HOISTS:

Attach one chain hoist to upright (as shown), using lift chain and chain hoist of suitable capacity, and the other to rear of truck as shown.

**N O T E**

Newer design chain slings have the safe lifting capacity indicated on end hook.

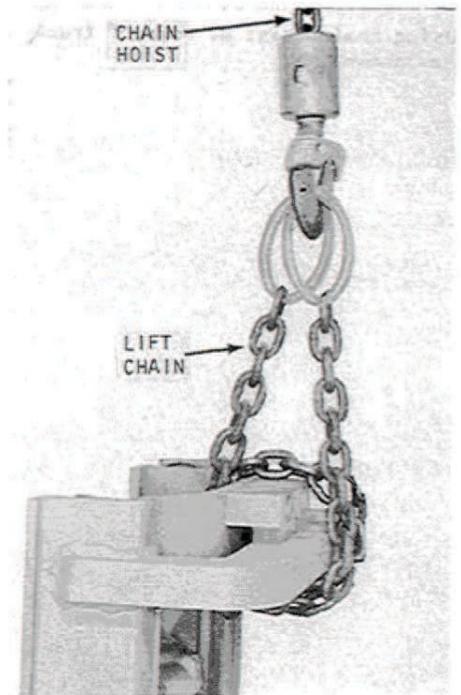

Fig. 16467

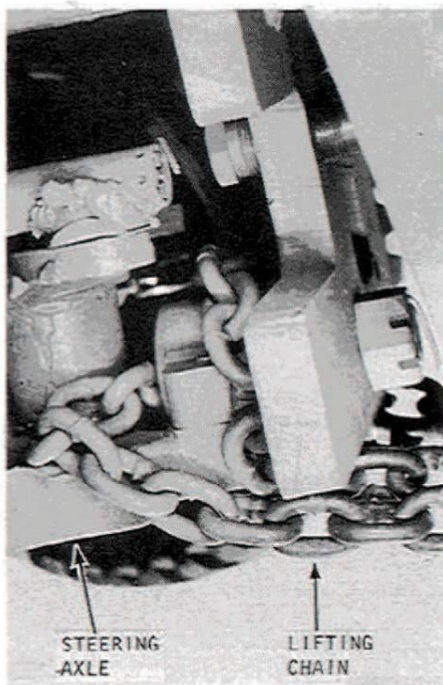

Fig. 16468

Wrapping Chain Around Steer Axle Fig. 16468

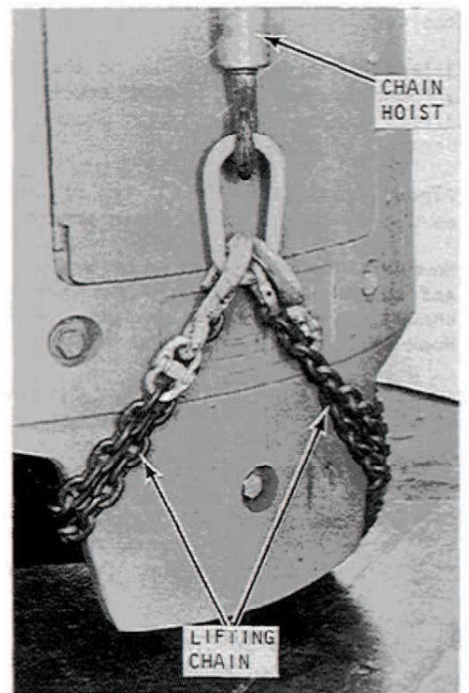

Fig. 16469

Bringing Ends Around Counterweight Fig. 16469

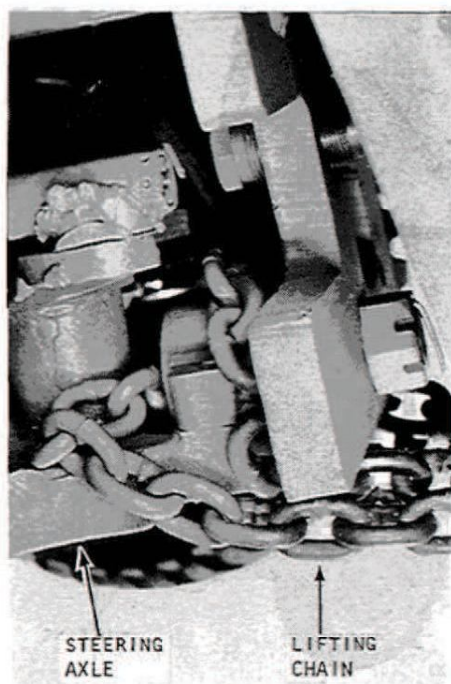

Fig. 16468

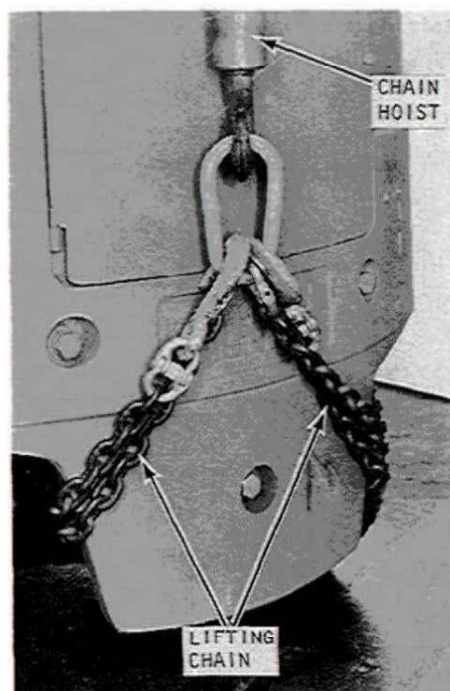

Fig. 16469

Using lift chain and hoist of suitable capacity (refer to Hoist and Chain recommendations in GROUP 40, Section 13), wrap lift chain around the steer axle near the rear trunnion of the electric truck to be up-ended and bring the ends of the lift chain around each side of the counterweight (not under the low part between the notches) and attach to the hoist.

**N O T E**

Since the batteries will have to be hoisted out of the truck, maximum weights are given for batteries used in each size truck, as well as drive motor weights (in the event that a drive motor is to be removed or swung down for servicing).

Raising counterweight end of truck.

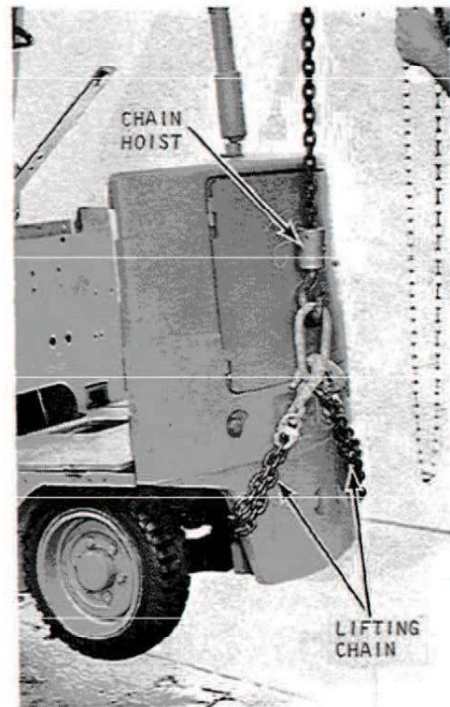

Fig. 16474

Using the hoist at the rear of the truck, carefully raise the counterweight end until the weight shifts to the "catch" truck, while lowering the forks on the "catch" truck at the same time. When the weight of the truck shifts to the "catch" truck so there is slack on the hoist, slowly lower the forks of the ...

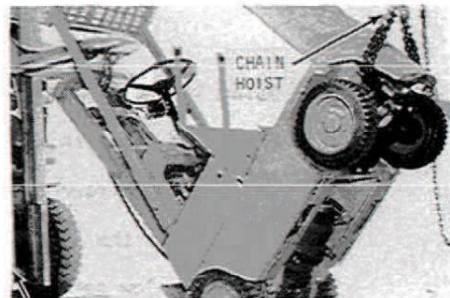

Fig. 16475

... "catch" truck until the upright is resting on the floor as shown in Fig. 16476.

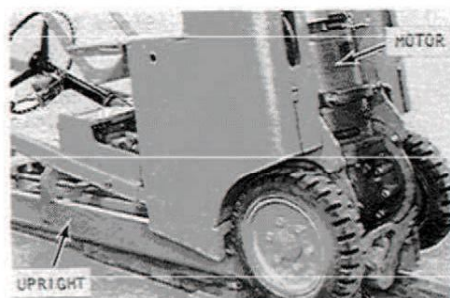

Fig. 16476

Remove motor support bracket.

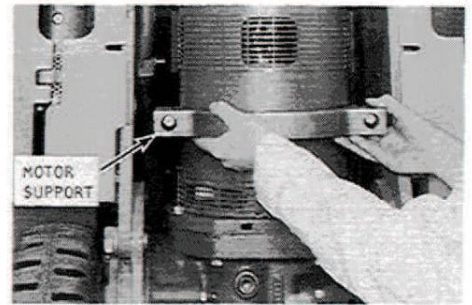

Fig. 16477

**N O T E**

For ease in moving motor away from frame, loosen the upright trunnion (12 point) cap screws 2 or 3 turns. Be sure to tighten screws after drive motor installation.

Using a pry bar against the commutator end frame (never distort the brake drum) and using the body frame as a fulcrum, push or pry the drive motor out away from truck frame (as shown in Fig. 16478).

**N O T E**

The drive axle is mounted on an eccentric and will move (with the wheels) toward the frame as the brake drum end is moved out from the frame. Keep pulling on the brake drum end of the drive motor until the wheels come in contact with the bottom of the truck frame, allowing sufficient clearance to pull the drive motor.

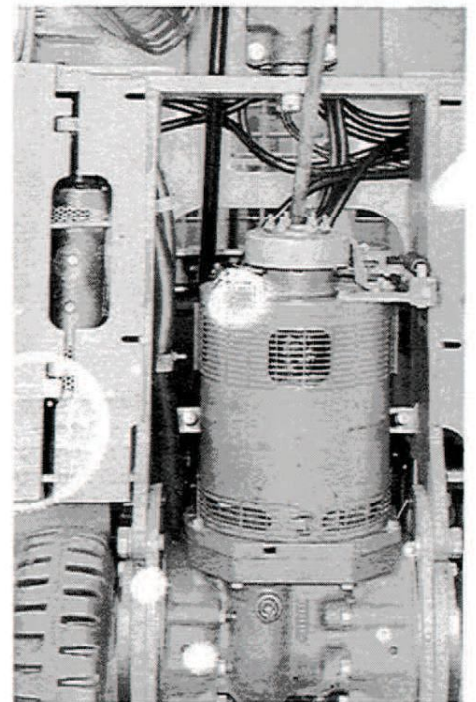

Fig. 16478

Disconnect all power cables from drive motor terminals (as shown in Fig. 16479).

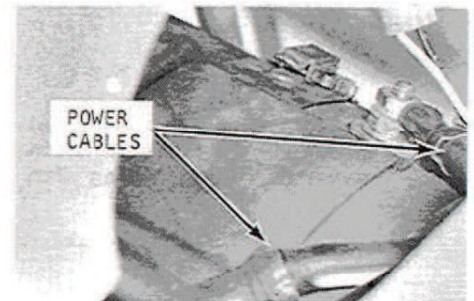

Fig. 16479

Remove the brake drum flange nut from the armature shaft (as shown in Fig. 16480).

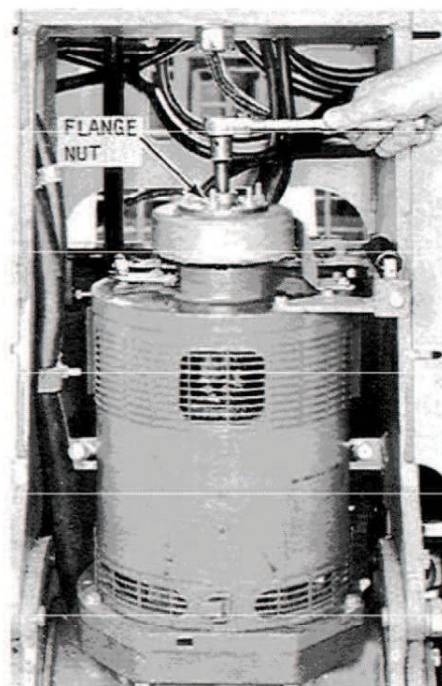

Fig. 16480

Install an eye bolt (to which a coupling nut or extra-heavy pipe coupling with internal threads to match the armature shaft has been affixed) on the end of the armature shaft, making sure there is at least four threads deep thread engagement on the shaft and on the eye bolt.

**NOTE**

It is not necessary to remove the brake drum before installing lifting eye.

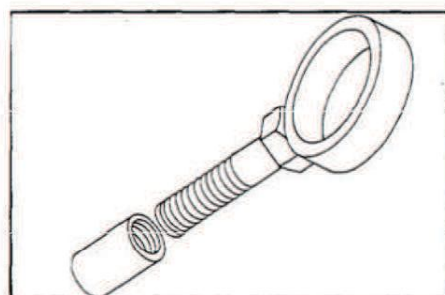

Fig. 16481

Connect a hoist or chain fall to the eye and place a slight tension on the chain.

**NOTE**

Trucks of the EC500 E685 model range are equipped with a resistor which must be removed before proceeding with removal of motor.

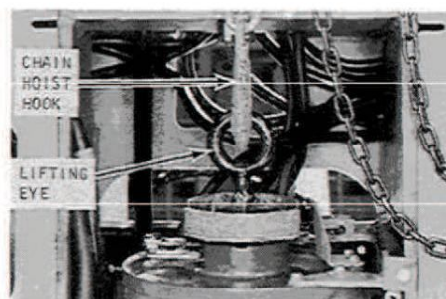

Fig. 16482

Maintain a slight tension on the hoist chain and remove the bolts retaining the drive motor to the differential housing (as shown in Fig. 16483).

**N O T E**

Some drive motors are manufactured with two tapped holes in the flange at the drive end, into which two of the bolts removed in Step 18 can be installed for use as jackscrews to separate the drive motor from the differential housing. Be sure to remove these bolts from the flange after hoisting drive motor, to avoid damage them when placing motor on drive end frame.

Raise drive motor with hoist or chain fall until clear of differential housing and place the motor (with the drive end frame down) on clean work surface for disassembly. Reinstall brake drum flange nut on end of armature shaft to protect the threads (as shown in Fig. 16484).

**N O T E**

To remove brake drum from drive motor, refer to instructions in GROUP 16, Section 6.

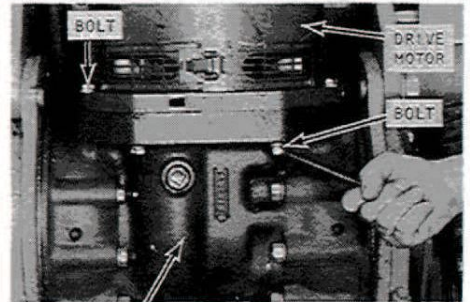

Fig. 16483

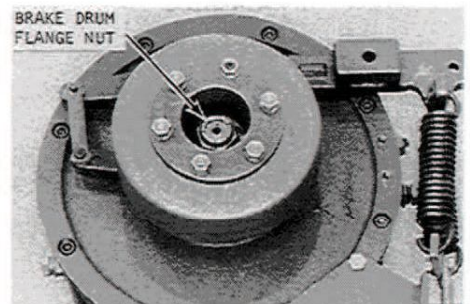

Fig. 16484

**BRAKE DRUM REMOVAL:**

To remove the brake drum from the drive motor on early model trucks equipped with short drum-to-flange bolts, it will be necessary to drill and tap two holes in the drum for insertion of jack-screws (as shown in Fig. 16485).

Disconnect the brake springs.

Rotate the brake drum so that the holes to be drilled in the bolt circle will be located at 3 and 9 o'clock, in relation to the installed drive motor location in the truck. This will clear all internal brake parts.

Remove the lifting eye bolt and nut (or extra heavy coupling) from the armature shaft, if the motor was pulled from the truck.

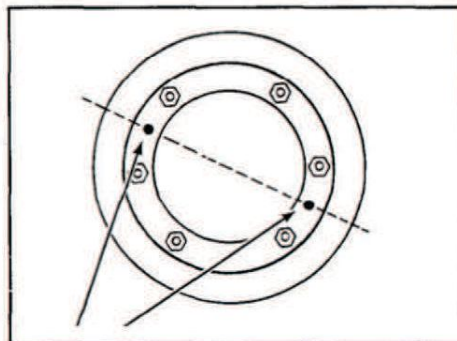

Fig. 16485

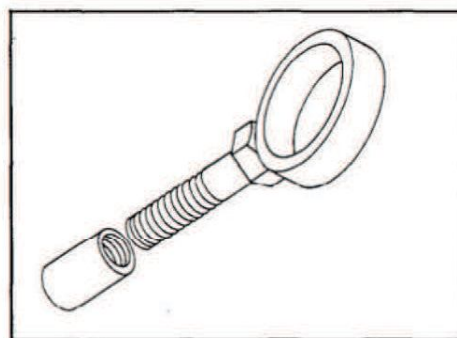

Fig. 16481

Drill two (5/16 inch) holes as outlined above.

Tap both holes with a 3/8 inch coarse thread tap.

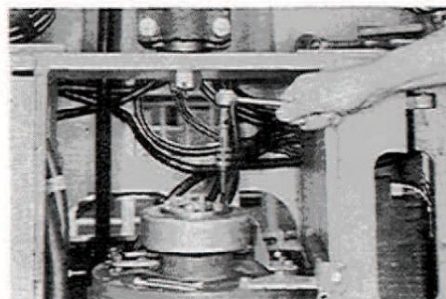

Fig. 16486

install two bolts into the tapped holes and tighten alternately until drum is free. Lift off drum.

**CAUTION**

DO NOT USE A PULLER TO REMOVE THE BRAKE DRUM.  
TWO- OR THREE-JAW PULLERS CAN DISTORT THE  
BRAKE DRUM.

**NOTE**

See next page for alternative method.

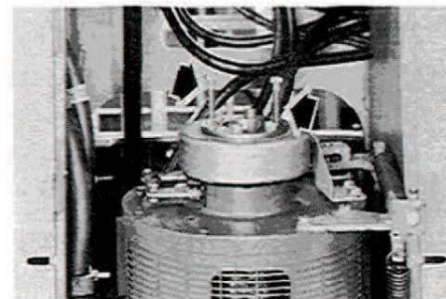

Fig. 16487

GROUP 16

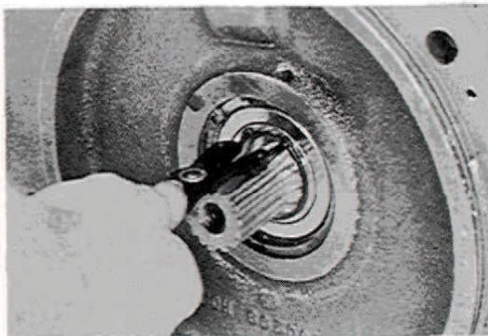

Fig. 11291

8. Use snap ring pliers to remove bearing snap ring (16.077) from armature shaft.

9. Tip drive motor so it rests on drive end frame, block securely, remove drive end to body bolts (16.068).

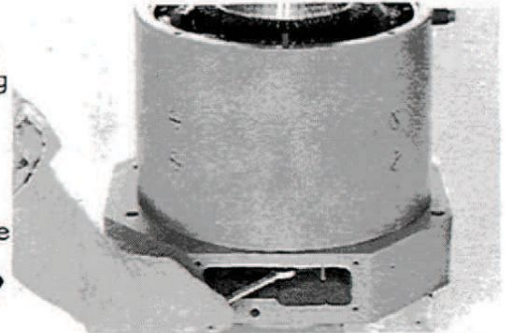

Fig. 11292

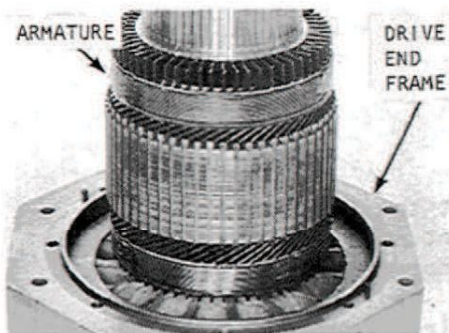

Fig. 16831

10. Lift motor body (33N) from drive end frame (16.078) by lifting it carefully over armature (16.011).

11. Field coils must be air cleaned and inspected. Remove only for repair or replacement.

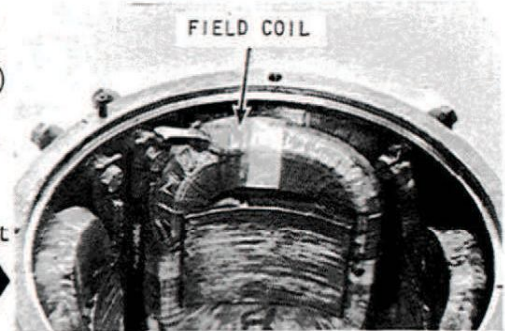

Fig. 11294

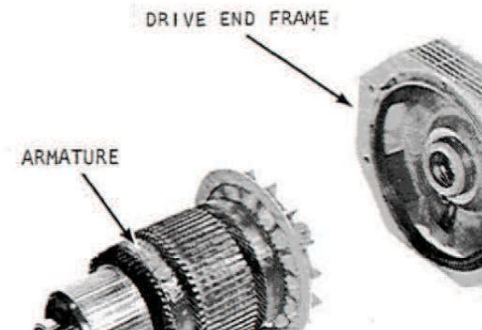

Fig. 11295

12. Separate the armature and shaft from motor drive end frame.

13. Use "puller" and thread protector to remove armature shaft commutator end bearing (16.002).

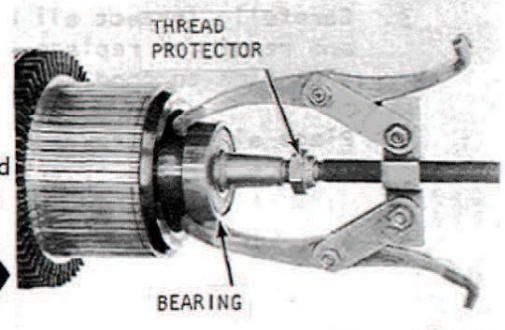

Fig. 16832

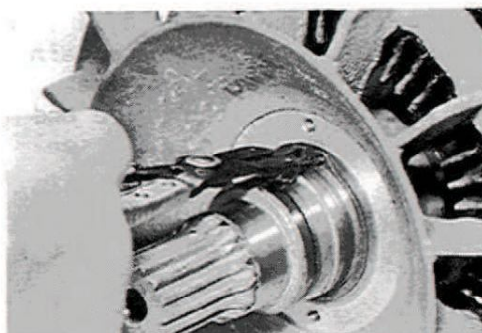

Fig. 11297

14. Use snap ring pliers to remove fan retaining snap ring (16.037).

15. Install puller bolts into tapped holes in fan, using "puller", remove fan (16.036) from armature shaft.

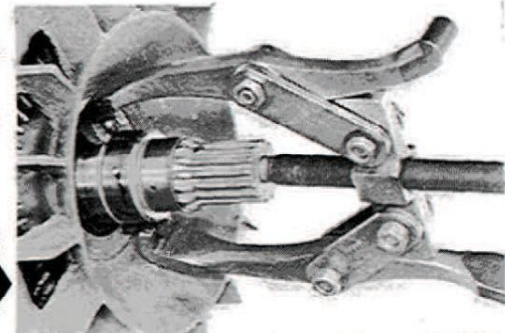

Fig. 11298