

SHOP MANUAL

KOMATSU

FB30,30S-2

MACHINE MODEL	SERIAL NO.
FB30-2	10001 and up
FB30S-2	20001 and up

 KOMATSU FORKLIFT CO., LTD.

FOREWORD

Only through correct operation, maintenance, trouble shooting, and repairs, can the effective performance, prevention of breakdowns and a long useful life of a machine be sustained.

The object of this "Shop Manual" is to furnish the information needed by the serviceman to perform his work well, by giving him the essential details precisely but in an easily understood format.

In performing his work, the serviceman should study the pertinent section of this manual carefully, and work systematically and scientifically by following the outlined work sequence.

This Shop Manual has been prepared with the above in mind, so that each basic part of the machine is dealt with under the headings: "Construction and Function", "Testing and Adjustments", "Trouble shooting", "Specifications" and "Disassembly and Assembly".

Also a section on General Technical Procedures is provided to furnish details on basic operations and procedures common to the serviceman's work on the different parts of the machine.

1. General Instructions

This section presents under one heading the basic information and procedures common to the section on "Disassembly and Assembly", "Testing and Adjustments", "Trouble shooting", and "Dismounting and Mounting". It is essential for the serviceman to thoroughly understand and know this section till it becomes a part of his common sense.

2. Construction and Function

This section gives a detailed explanation of the "Construction" with details and drawings of the "Constituent Parts" and "block" or "circuit" diagrams, arranged for the serviceman, but also useful as a textbook for training service personnel. However, in the latter case Training Aids should be used to cover the basic theory not included in this manual.

3. Testing and Adjustments

Procedures of all the necessary "Tests" and "Adjustments" are described with photographs showing the necessary measuring equipment and the location for making the measurements. This should aid the serviceman in his trouble shooting, checking and adjusting work.

4. Trouble Shooting

Typical common troubles are listed and systematically described; with their causes and the procedures for finding and diagnosing the symptoms.

As it is impossible to list all of the possible troubles, the serviceman should study the section covering the "Construction and Function" and "Testing and Adjustments" and apply this knowledge to diagnose any non-listed troubles.

5. Specifications

In this section, all standard dimensions and tolerance that are necessary to perform Testing and Adjustments are presented; with drawings together with, appropriate procedures for disassembly and assembly, performing repairs, or trouble shooting. However, basic diamensions and tolerances, for repairs or rebuilding, are limited to those machine parts most commonly worked on.

DISASSEMBLY DIAGRAMS

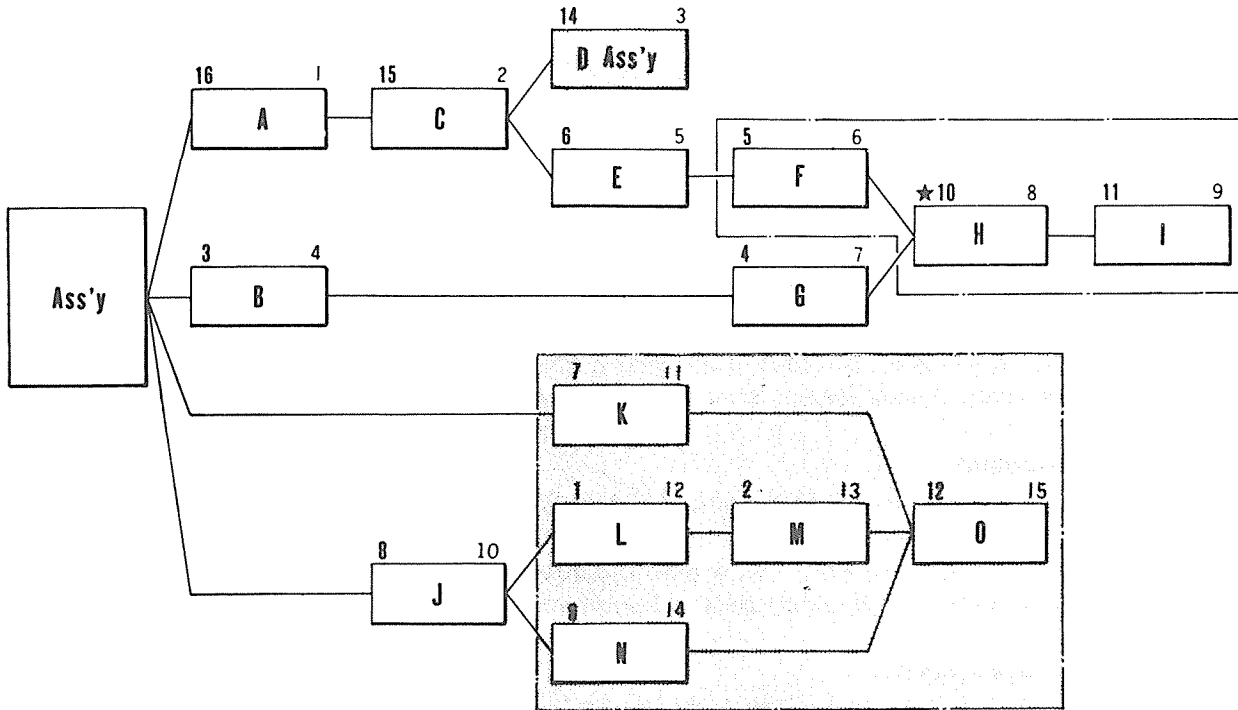



DISASSEMBLY DIAGRAMS

HOW TO READ THE DIAGRAMS

Sequential procedure to be followed when disassembling a machine or its components are illustrated in these manuals in the form of a diagram; no sentential descriptions are provided. Therefore, you are required to be familiar with such diagrams by thoroughly understanding the following descriptions. The disassembling diagrams include the following information:

- Sequential procedure to be followed when disassembling a machine or a component thoroughly
- The shortest procedure which requires the minimum number of parts to be removed from the machine prior to removal of a desired component part
- The same as above necessary to remove a desired assembly

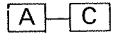
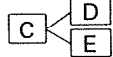
In the diagram shown as an example on the preceding page, the name of machine (or assembly) to be disassembled is shown in the square at far left. All other squares represent parts or sub-assemblies to be removed from the preceding parts or sub-assembly. Mutual relations between the parts (or sub-assembly) can be classified as follows:

-  "C" can not be removed unless "A" is removed.
-  Both "D" and "E" can be removed after "C" is removed.
-  "H" cannot be removed unless both "F" and "G" are removed.
- This indicates an assembly composed of enclosed parts such as "F", "H" and "I". To remove these parts as an assembly, it is necessary to remove previously all parts connected to the lines leading from the left-hand edge of the block.

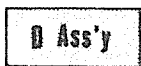

This is an assembly of which the disassembling procedure is described separately.

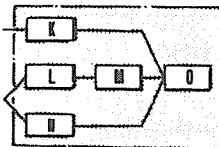

This indicates an assembly composed of enclosed parts. All of the enclosed parts may be removed individually according to the procedure shown by this diagram, or may be removed first as an assembly and then divided into individual parts according to the separately illustrated disassembly diagram.

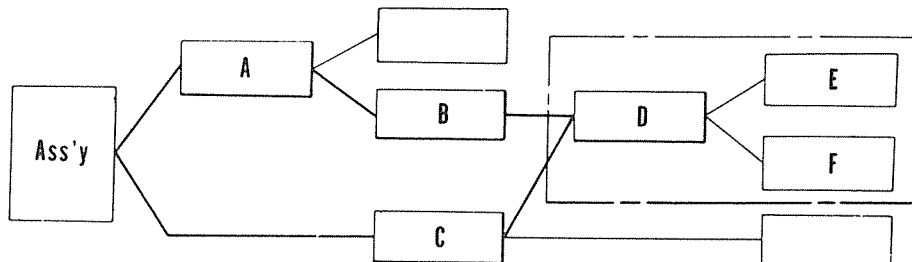

When a part (or an assembly) in the diagram is specified as an object to be removed, trace all paths leading the specified part (or the block of the specified assembly) to the original machine (or assembly) located at the far left of the diagram. The parts arranged in such paths are the minimum parts necessary to be removed. In the diagram above, for example, the part "D" (or an assembly composed of "D", "E" and "F") can be removed after removing only the parts "A", "B" and "C" arranged on the thick lines.

ASSEMBLY DIAGRAM

The same manner as described above to read the disassembly drawings are also applicable to the assembly drawings. A part (machine chassis, case, etc.) with which the assembling procedure is to be started is indicated in the square located at the far left end in the diagram. All other squares represent parts (or sub-assemblies) to be installed to the preceding parts or sub-assemblies.

In the assembly diagrams, in which all parts are arranged in the sequence of assembly from left to right, the parts have mutual relations with each other as shown in the following:

- "B" cannot be installed unless "A" is installed.
- Both "D" and "E" can be installed after "C" is installed.
- "H" cannot be installed unless both "F" and "G" are installed.

All marks and numerals have the same designations as described for the disassembly diagram.

SYMBOL AND NUMERALS ABOVE A SQUARE



- The mark * is a reference to a note describing the precautions to be followed when removing the part.
- The boldface numeral located at the top left of a square corresponds to the index number used in the structural drawing to indicate that part. Only in the disassembly diagram indicating the general disassembly of a machine (or an assembly), however, is another form of numerals such as 12-24 used, 12 corresponds to the item code number used on each page as part of the page numbers, and 24 corresponds to the index number used in the structural drawing.
- The numeral located at the top right of a square indicates the disassembling order recommended by Komatsu.

PRECAUTIONS WHEN PERFORMING THE SERVICE WORK

Always pay attention to, Safety, before starting any work – this is important.
Never attempt any work where danger to yourself or to other persons.
Whenever work requiring safety precautions are described in this manual, a flag mark  is inserted, always make double sure that safety measures are taken.
Other unmarked work, should always be performed after studying and using your common sense to prevent accidents.

DESCRIPTION OF THE SYMBOLS

The symbols described below are used in this manual for convenience and better understanding.

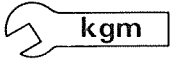
Symbol	Item	Discription
	Safety	Special safety precautions are needed to perform the work.
	Note	Special technical precautions are needed to perform the work.
	Tightening Torque	Fastening parts that require specified tightening force when assembling.

GENERAL

General views 01 - 2
Specifications 01 - 4
General assembly drawing 01 - 6

GENERAL VIEWS

FB30-2

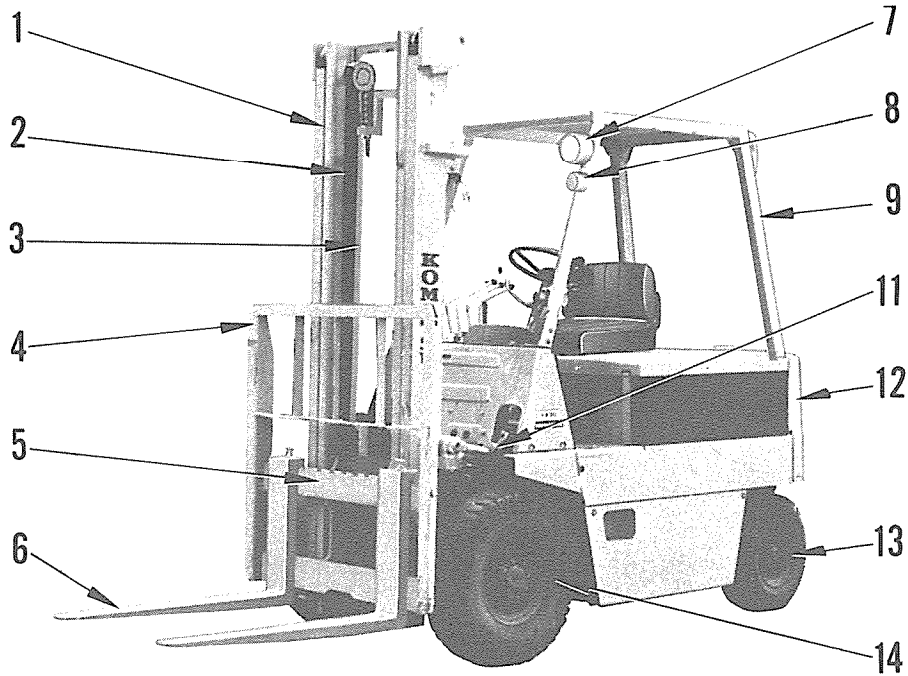

FB30P001

- | | |
|-----------------------|------------------------------|
| 1. Mast | 8. Turn signal lamp (Option) |
| 2. Lift chain | 9. Overhead guard |
| 3. Lift cylinder | 11. Tilt cylinder |
| 4. Back rest | 12. Counterweight |
| 5. Finger bar | 13. Rear wheel |
| 6. Fork | 14. Front wheel |
| 7. Head lamp (Option) | |

MACHINE MODEL AND SERIAL NUMBER

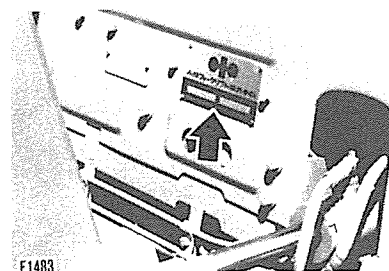
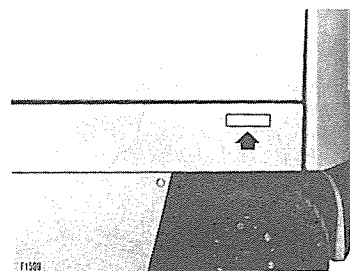

FB30S-2

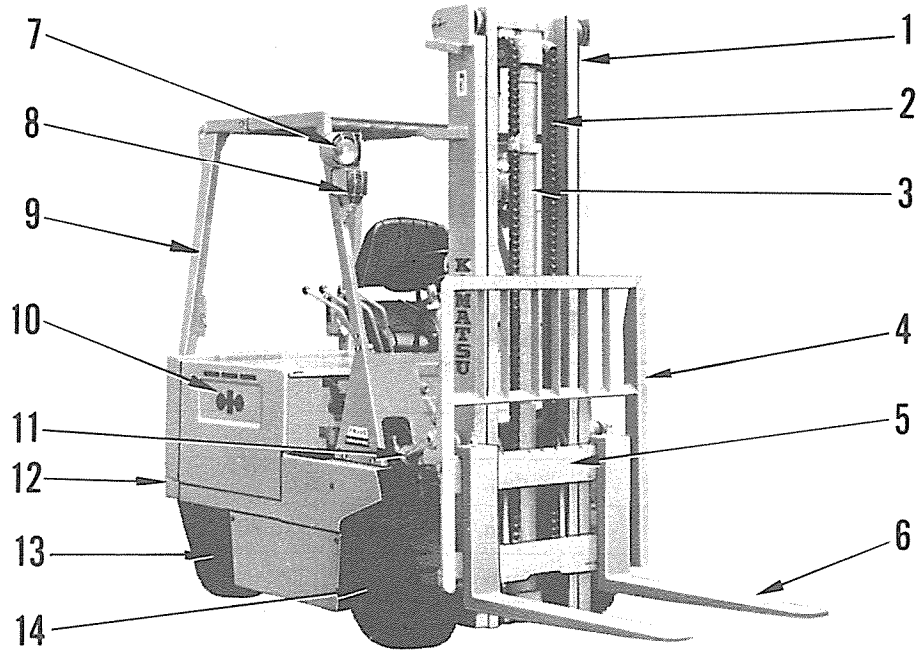

FB30P002

- 1. Mast
- 2. Lift chain
- 3. Lift cylinder
- 4. Back rest
- 5. Finger bar
- 6. Fork
- 7. Head lamp (Option)
- 8. Turn signal lamp (Option)
- 9. Overhead guard
- 10. Battery side cover
- 11. Tilt cylinder
- 12. Counterweight
- 13. Rear wheel
- 14. Front wheel

MACHINE MODEL AND SERIAL NUMBER

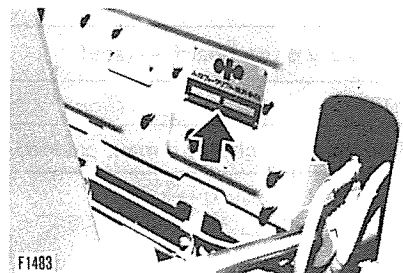
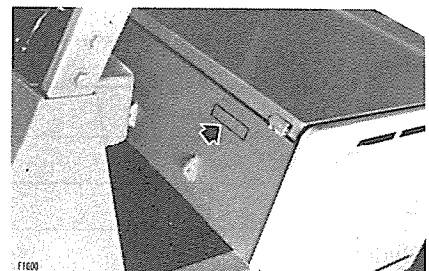

SPECIFICATIONS

Class	Item		FB30-2	FB30S-2		
Performance	Load capacity	kg	3,000	3,000		
	Load center	mm	500	500		
	Max. fork height	mm	3,000	3,000		
	Free lift	mm	160 (410)	410		
	Tilting angle (Forward & backward)	deg.	6/12	6/10		
	Lifting speed	Unloaded	mm/s	330 (350)	290	400
		Loaded	mm/s	230 (240)	210	280
	Traveling speed	Unloaded	km/h	16	11	15
		Loaded	km/h	13	9.5	13
	Gradeability (Loaded)	deg.	8.8	6.2	7.2	
	Min. right angle stacking aisle	mm	3,800 (3,870)	3,465		
	Turning radius outside	mm	2,300	2,000		
Dimensions	Overall length (Incl. fork)	mm	2,605 (2,595)	2,190		
	Fork length	mm	1,070	1,070		
	Overall width	mm	1,200	1,090		
	Overall height	Mast	mm	2,015	1,960	
		Overhead guard	mm	2,315	2,150	
	Wheelbase	mm	1,700	1,320		
	Tread (Front/rear)	mm	965/960	875/850		
Under clearance	mm	130	80			
Weight	Service weight	Without battery	kg	3,550 (3,535)		
		With battery	kg	4,740 (4,725)		
Tire	Front		8.25-12-12PR		21 x 8 x 15	
	Rear		6.50-10-10PR		16 x 6 x 10½	
Battery	Width x Length x Height	mm	1,178 x 1,010 x 550		1,005 x 815 x 594	
	Volt/Capacity (max.)	V/AH5hr	72/440 (480,560)		36/1020 48/680 (765)	
Motor	Drive motor	KW	8.5	5.6	8	
	Hydraulic motor	KW	12.5	10	14	
	PS motor	KW	1.2	0.6	0.75	
Char-ger	Stationary or on board — rated	V	Stationary — 190 ~ 229		Stationary — 190 ~ 229	
Mast	Type		Free view mast		Standard mast	
	Max. lifting height with max. payload	mm	4,000		4,000	

GENERAL ASSEMBLY DRAWING

FB30-2

