

シヨツプマニユアル

LEO-AX

シヨツプマニユアル

LEO-NEXT

エンジン式フォークリフト

機 種	適 用 号 機
AX	
FG10/14/15/18-18	M210-640001~
FG09L/10L/14L/15L/18L-18	M209-640001~
FG15H/18H-18	M211-640001~
FG10/14/15/18-18	M213-640001~
FG10L/14L/15L/18L-18	M213-640001~

KOMATSU

小松リフト
Komatsu Forklift Co., Ltd.

CONTENTS

	Page No.
INTRODUCTION	9
EMISSION CONTROL STATEMENTS	10
MODEL TABLE	16
1. SAFETY	
1.1 SAFETY MANAGEMENT	1-2
1.2 SAFE TRAVEL	1-5
1.3 LOADING OPERATIONS	1-12
1.4 SAFETY IN PERIODIC MAINTENANCE	1-16
1.5 TOWING	1-22
1.6 STRUCTURE AND STABILITY OF THE LIFT TRUCK	1-23
2. SPECIFICATIONS AND GENERAL INFORMATION	
2.1 TRUCK DATA - PNEUMATIC TIRE LIFT TRUCKS (OUTDOOR)	2-4
2.2 TRUCK DATA - CUSHION TIRE LIFT TRUCKS (INDOOR)	2-6
2.3 AX50 SERVICE DATA - ALL MODELS	2-8
2.4 WEIGHT TABLE	2-10
2.5 SPECIFICATIONS	2-12
2.6 PERIODIC REPLACEMENT OF CONSUMABLE PARTS	2-13
2.7 STANDARD TIGHTENING TORQUE FOR BOLTS	2-14
2.8 STANDARD TIGHTENING TORQUE FOR PIPE JOINTS	2-15
2.8.1 ELBOWS, NIPPLES AND UNIONS	2-15
2.8.2 HIGH-PRESSURE RUBBER HOSES, PIPES AND SLEEVE NUTS	2-15
2.9 LUBRICANT AND FUEL CAPACITIES	2-16
3. OPERATOR COMPARTMENT	
3.1 STRUCTURE AND FUNCTION	3-2
3.1.1 VEHICLE CONTROLLER	3-2
3.1.1 KOMATSU OPERATOR PRESENT SYSTEM (KOPS)	3-2
3.1.2 CONTROLLER TROUBLESHOOTING	3-3
3.2 PERIODIC INSPECTION AND MAINTENANCE	3-6
3.3 TESTING AND ADJUSTING	3-7
3.3.1 ADJUST STOP LAMP SWITCH	3-8
3.3.2 ADJUST ACCELERATOR PEDAL	3-9
3.3.3 ADJUST PARKING BRAKE LEVER	3-10
3.3.4 COMBINATION SWITCH	3-11
3.4 REMOVAL AND INSTALLATION	3-13
3.4.1 PARKING BRAKE CABLE	3-13
3.5 DISASSEMBLY AND ASSEMBLY	3-14
3.6 MAINTENANCE STANDARD	3-14

4. ENGINE

4.1	STRUCTURE AND FUNCTION	4-2
4.2	PERIODIC INSPECTION AND MAINTENANCE	4-3
4.2.1	LUBRICANTS CHART	4-3
4.2.2	MAINTENANCE INTERVALS	4-4
4.2.3	INSPECTION STANDARDS	4-6
4.2.4	CHECK COOLANT LEVEL	4-11
4.2.5	CHECK OIL LEVEL IN ENGINE OIL PAN	4-11
4.2.6	CHANGE ENGINE OIL	4-11
4.2.7	REPLACE ENGINE OIL FILTER	4-12
4.2.8	INSPECT THE SPARK PLUGS	4-12
4.2.9	DRAIN WATER FROM FUEL FILTER	4-12
4.2.10	REPLACE FUEL FILTER	4-13
4.2.11	REPLACE RADIAL SEAL AIR FILTER	4-13
4.2.12	CLEAN RADIATOR	4-14
4.3	TESTING AND ADJUSTING	4-15
4.3.1	ADJUST IGNITION TIMING	4-15
4.3.2	MEASURE COMPRESSION PRESSURE	4-16
4.3.3	ADJUSTMENT OF VALVE CLEARANCE	4-16
4.4	REMOVAL AND INSTALLATION	4-18
4.4.1	REMOVAL	4-18
4.4.2	INSTALLATION	4-20
4.5	DISASSEMBLY AND ASSEMBLY	4-24
4.6	MAINTENANCE STANDARD	4-24

5. TORQUE CONVERTER

5.1	STRUCTURE AND FUNCTION	5-2
5.1.1	TORQUE CONVERTER	5-2
5.1.2	GEAR PUMP	5-2
5.1.3	TORQUE CONVERTER ASSEMBLY	5-2
5.2	PERIODIC INSPECTION	5-10
5.2.1	TROUBLESHOOTING	5-11
5.3	TESTING AND ADJUSTING	5-13
5.4	REMOVAL AND INSTALLATION	5-13
5.5	DISASSEMBLY AND ASSEMBLY	5-14
5.5.1	DISASSEMBLY	5-14
5.5.2	ASSEMBLY	5-19
5.6	MAINTENANCE STANDARD	5-21

6. TORQFLOW TRANSMISSION

6.1	STRUCTURE AND FUNCTION	6-2
6.2	PERIODIC INSPECTION AND MAINTENANCE	6-5
6.2.1	INSPECTION STANDARDS	6-5
6.2.2	CHECK OIL LEVEL	6-6
6.2.3	REPLACE OIL, INSPECT AND CLEAN STRAINER	6-7
6.2.4	REPLACE LINE FILTER	6-7
6.3	TESTING AND ADJUSTING	6-7

6.4	REMOVAL AND INSTALLATION	6-8
6.4.1	REMOVAL.....	6-8
6.4.2	INSTALLATION.....	6-11
6.5	DISASSEMBLY AND ASSEMBLY.....	6-15
6.5.1	DISASSEMBLY.....	6-15
6.5.2	ASSEMBLY.....	6-21
6.6	MAINTENANCE STANDARD	6-27
6.6.1	TORQFLOW TRANSMISSION.....	6-27
6.6.2	TRANSMISSION CONTROL VALVE	6-29

7. DRIVE AXEL

7.1	STRUCTURE AND FUNCTION.....	7-2
7.2	PERIODIC INSPECTION AND MAINTENANCE.....	7-5
7.3	TESTING AND ADJUSTING	7-6
7.3.1	CHECK OIL LEVEL.....	7-6
7.3.2	REPLACE OIL.....	7-6
7.4	REMOVAL AND INSTALLATION	7-7
7.4.1	REMOVAL.....	7-7
7.4.2	INSTALLATION.....	7-9
7.5	DISASSEMBLY AND ASSEMBLY.....	7-11
7.5.1	ADJUST PINION SHAFT ASSEMBLY WITH SHIM(S).....	7-13
7.5.2	ADJUST PINION GEAR CLEARANCE.....	7-13
7.5.3	INSPECT PINION BEARING CLEARANCE.....	7-14
7.5.4	ADJUST DIFFERENTIAL	7-14
7.6	MAINTENANCE STANDARD	7-18

8. STEERING SYSTEM

8.1	STRUCTURE AND FUNCTION.....	8-2
8.1	STEERING VALVE.....	8-4
8.2	STEERING AXLE.....	8-6
8.3	PERIODIC INSPECTION AND MAINTENANCE.....	8-7
8.4	TESTING AND ADJUSTING	8-9
8.4.1	STEERING VALVE TROUBLESHOOTING CHART.....	8-9
8.5	REMOVAL AND INSTALLATION	8-12
8.5.1	STEERING VALVE.....	8-12
8.5.2	POWER STEERING CYLINDER	8-13
8.5.3	STEERING AXLE	8-14
8.6	DISASSEMBLY AND ASSEMBLY.....	8-16
8.6.1	STEERING VALVE.....	8-16
8.6.2	POWER STEERING CYLINDER	8-35
8.6.3	STEERING AXEL	8-38
8.7	MAINTENANCE STANDARD	8-41
8.7.1	POWER STEERING VALVE.....	8-41
8.7.2	STEERING AXLE	8-42

9. WHEEL BRAKE

9.1	STRUCTURE AND FUNCTION.....	9-2
9.1.1	WHEEL BRAKE	9-2
9.1.2	BRAKE MASTER CYLINDER.....	9-3

9.2	PERIODIC INSPECTION AND MAINTENANCE	9-4
9.2.1	INSPECTION STANDARDS	9-5
9.2.2	BLEEDING BRAKE PIPING	9-9
9.2.3	ADJUST INCHING AND BRAKE PEDAL	9-11
9.3	REMOVAL AND INSTALLATION	9-12
9.3.1	REMOVAL	9-12
9.3.2	INSTALLATION	9-12
9.4	DISASSEMBLY AND ASSEMBLY	9-14
9.4.1	WHEEL BRAKE	9-14
9.4.2	BRAKE MASTER CYLINDER	9-16
9.5	MAINTENANCE STANDARD	9-18
9.5.1	WHEEL BRAKE COMPONENTS	9-18
9.5.2	BRAKE MASTER CYLINDER	9-19

10. HYDRAULIC SYSTEM

10.1	STRUCTURE AND FUNCTION	10-2
10.2	PERIODIC INSPECTION AND MAINTENANCE	10-3
10.2.1	SERVICE HYDRAULIC TANK	10-5
10.3	REMOVAL AND INSTALLATION	10-6
10.3.1	REMOVE HYDRAULIC PUMP	10-6
10.3.2	INSTALL HYDRAULIC PUMP	10-6
10.4	DISASSEMBLY AND ASSEMBLY	10-7
10.4.1	HYDRAULIC PUMP	10-7
10.4.2	CONTROL VALVE	10-12
10.4.3	REPLACE CONTROL VALVE LIP SEALS	10-16
10.4.4	REPLACE CONTROL VALVE SPOOL SEALS	10-17
10.5	MAINTENANCE STANDARD	10-18

11. WORK EQUIPMENT

11.1	STRUCTURE AND FUNCTION	11-2
11.1.1	TILT CYLINDER	11-2
11.2	PERIODIC INSPECTION AND MAINTENANCE	11-4
11.3	MEASURE HYDRAULIC DRIFT OF LIFT AND TILT CYLINDERS	11-6
11.4	REMOVAL AND INSTALLATION	11-7
11.4.1	MAST	11-7
11.4.2	LIFT CYLINDER	11-8
11.5	DISASSEMBLY AND ASSEMBLY	11-10
11.5.1	LIFT CYLINDER	11-10
11.5.2	TILT CYLINDER	11-18
11.5.3	CYLINDER SEAL SERVICE KITS	11-22
11.5.4	SIDESHIFTER	11-27
11.6	MAINTENANCE STANDARD	11-54
11.6.1	MAST, FORK CARRIAGE AND FORK	11-57

12. ES30/ES40 MS LIMITED FREE LIFT 2-STAGE MAST

INTRODUCTION.....	12-2
INSTALLATION.....	12-3
PERIODIC MAINTENANCE.....	12-7
TROUBLESHOOTING.....	12-8
SERVICE.....	12-9

13. ES30/ES40, E40/E50/E60/E65, EV40/EV50/EV60 FULL FREE LIFT 3-STAGE MAST

INTRODUCTION.....	13-2
INSTALLATION.....	13-4
PERIODIC MAINTENANCE.....	13-19
TROUBLESHOOTING.....	13-20
SERVICE.....	13-21

14. 35D/45D/55D MQ QUAD MAST

14.1 INTRODUCTION.....	14-2
14.2 INSTALLATION INSTRUCTIONS.....	14-3
14.3 PERIODIC MAINTENANCE.....	14-16
14.4 TROUBLESHOOTING.....	14-18
14.5 SERVICE.....	14-19

15. CONVERSION TABLES

MILLIMETERS TO INCHES.....	15-2
INCHES TO MILLIMETERS.....	15-2
CUBIC METERS TO CUBIC YARDS.....	15-2
CUBIC YARDS TO CUBIC METERS.....	15-3
LITER TO U.S. GALLON.....	15-3
U. S. GALLON TO LITER.....	15-3
LITER TO U.K. GALLON.....	15-4
U. K. GALLON TO LITER.....	15-4
KILOGRAM TO POUND.....	15-4
POUND TO KILOGRAM.....	15-5
KG/CM ² TO LB/IN ²	15-5
KGM TO FT. LB.....	15-6
TEMPERATURE (FAHRENHEIT/CENTIGRADE).....	15-6

APPENDIX

APPENDIX A- ELECTRICAL DIAGRAMS

- AX50 EPA TORQFLOW - GASOLINE ENGINE
- AX50 EPA TORQFLOW - GASOLINE/LP DUAL-FUEL ENGINE
- AX50 EPA TORQFLOW - LPG ENGINE
- AX50 EPA TORQFLOW - UL-EE LP ENGINE
- AX50-BX50 CARB2010 GASOLINE/LP DUAL-FUEL ENGINE
- AX50-BX50 CARB2010 LPG ENGINE

NOTES:

INTRODUCTION

This Service Manual has been developed as an information resource to help the reader learn about, understand, repair and maintain the AX50 Series forklift trucks, and the various equipment, systems, inspections, sensors, diagnostic procedures and diagnostic equipment utilized to maintain, adjust and troubleshoot these systems. Although reference is made to maintenance procedures necessary to perform servicing of this vehicle, you should refer to the applicable *Operation and Maintenance Manual* for these lift trucks for more complete maintenance information.

Komatsu is involved in a concentrated and highly technical program of designing and developing cleaner burning, more efficient and more powerful engines for use in the industrial truck market. As a result, new computerized sensors, systems and diagnostic monitors have been created to make the job of maintaining and repairing these systems simple and easy.

Read this manual carefully, refer to it often and learn the repair, testing and adjustment procedures to the best of your ability. Please note that some illustrations are generic and may not look exactly like your unit in every detail.

Ensure that, when you are working on or around industrial trucks, **Safety is priority Number One**. Read, understand and obey all **WARNINGS** and **CAUTIONS**.

Follow the instructions and procedures presented in this manual when working on these lift trucks and their systems. Damage to the equipment, and possible injury to yourself or others, may result if these procedures are not adhered to carefully.

Keep this manual nearby and accessible for use when necessary. If this book becomes dirty, worn or illegible, contact Komatsu for a replacement. The procedures outlined in this manual will be updated periodically. Be sure that you have the latest revision in order to learn the newest information available. Revision dates will be clearly displayed on the lower left hand corner of the cover page.

This will aid in maintaining your equipment in excellent condition and in ensuring that these lift trucks will operate safely at maximum efficiency.

ENGINE SERIAL NUMBER LOCATION

The K21/K25 engine serial number is stamped on an angled and machined pad on the right side of the engine block in the center just beneath the valve cover.

The machined boss is split vertically by a groove. The Engine Model number is on the left pad and the Engine Serial number is on the right pad.

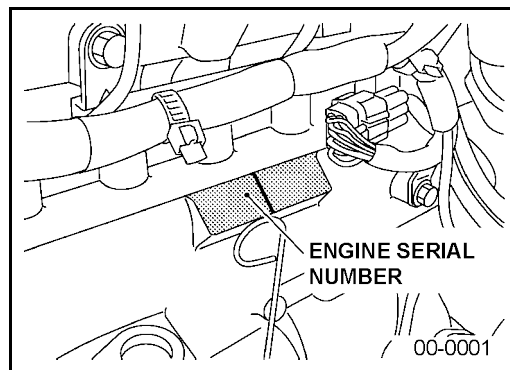

EMISSION CONTROL STATEMENTS

CALIFORNIA/FEDERAL EMISSION CONTROL STATEMENT FOR OFF-ROAD LSI (NON-DIESEL) ENGINES (K21 AND K25 ENGINES)

This section presents information concerning the correct labeling, warranty, parts and maintenance of K21 and K25 engines in order to comply with the EPA and CARB off-road, large-spark-ignition (LSI) engine regulations.

LABELS REQUIRED AND LABEL LOCATIONS

All "K" series engines will display the required identification label as follows.

Location on K21/K25 Series engines:

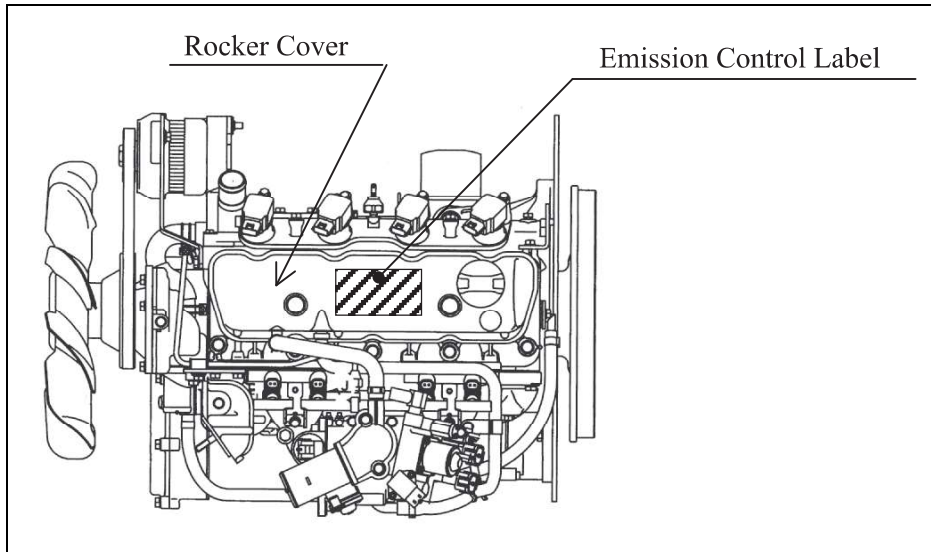

Emission compliance label (sample):

EMISSION CONTROL INFORMATION		2006	SEP					
ENGINE FAMILY:7NSXB02.548C, ENGINE DISPLACEMENT: 2.5 LITER THIS ENGINE IS CERTIFIED TO OPERATE ON GASOLINE AND LPG. EXHAUST EMISSION CONTROL TYPE: MPI, TBI, TWC, HO2S USE IN VARIABLE-SPEED APPLICATIONS ONLY			2007	OCT				
<table border="1"> <tr> <td>IDLE SPEED</td> <td>NO OTHER ADJUSTMENTS NEEDED</td> </tr> <tr> <td>VALVE LASH</td> <td>0.38 mm (HOT)</td> </tr> <tr> <td>SPARK PLUG GAP</td> <td>0.9 mm</td> </tr> </table>		IDLE SPEED		NO OTHER ADJUSTMENTS NEEDED	VALVE LASH	0.38 mm (HOT)	SPARK PLUG GAP	0.9 mm
IDLE SPEED	NO OTHER ADJUSTMENTS NEEDED							
VALVE LASH	0.38 mm (HOT)							
SPARK PLUG GAP	0.9 mm							
NO OTHER ADJUSTMENTS NEEDED. CARB EMISSION STANDARDS : HC+NOx=1.0, CO=8.3 g/bhp-hr EPA Tier2 EMISSION STANDARDS : HC+NOx=1.3, CO=11.1 g/kW-hr			DEC					
THIS ENGINE COMPLIES WITH CALIFORNIA AND U.S. EPA REGULATIONS FOR 2007 LARGE NONROAD SI ENGINES.			JAN					
NISSAN MOTOR CO., LTD.	K25 D		FEB					
			MAR					
			APR					
			MAY					
			JUN					
			JUL					
			AUG					
			SEP					
			OCT					
			NOV					
			DEC					

WARRANTY

The following statement is required to be provided by regulations of the California Air Resources Board.

YOUR WARRANTY RIGHTS AND OBLIGATIONS

The California Air Resources Board is pleased to explain the emission control system warranty on your 2008 engine. In California, new off-road large spark-ignition (LSI) engines must be designed, built and equipped to meet the state's stringent anti-smog standards.

Komatsu Forklift U.S.A. LLC. ("KFI") must warrant the emission control system on your engine for the periods of time listed below provided there has been no abuse, neglect or improper maintenance of your engine.

Your emission control system may include parts such as the carburetor, regulator or fuel-injection system, ignition system, engine computer unit (ECM), catalytic converter and air induction system.

Also included may be sensors, hoses, belts, connectors and other emission-related assemblies.

Where a warrantable condition exists, an Authorized KFI Dealer will repair your LSI engine at no cost to you including diagnosis, parts and labor.

MANUFACTURER'S WARRANTY COVERAGE

The 2008 off-road large spark-ignition engines are warranted for the time periods as listed below.

If any emission-related part on your engine is defective, the part will be repaired or replaced by an Authorized KFI Dealer.

OWNER'S WARRANTY RESPONSIBILITIES

As the off-road LSI engine owner, you are responsible for the performance of the required maintenance listed in your Operation and Maintenance Manual.

KFI recommends that you retain receipts covering maintenance on your off-road engine, but KFI cannot deny warranty solely for the lack of receipts or for your failure to ensure the performance of all scheduled maintenance.

As the off-road large spark-ignition engine owner, you should however be aware that KFI may deny you warranty coverage if your off-road large spark-ignition engine or a part thereof has failed due to abuse, neglect, improper maintenance or unapproved modifications.

Your engine is designed to operate on gasoline or LPG fuel. Use of any other fuel may result in your engine no longer operating in compliance with California's emissions requirements.

You are responsible for initiating the warranty process. The ARB suggests that you present your off-road large spark-ignition engine to an Authorized KFI Dealer as soon as a problem exists.

The warranty repairs should be completed by the Dealer as expeditiously as possible.

If you have any questions regarding your warranty rights and responsibilities, you should contact KFI's Product Support Department at 1-847-437-5800.

EMISSION CONTROL WARRANTY - 36 MONTHS or 2,500 HOURS FOR GENERAL PARTS

For the first 2,500 operating hours or for a period of thirty-six months from the date of the first use by the original purchaser from an Authorized KFI Dealer, whichever occurs first, KFI warrants the following emission-related parts.

- Oxygen sensor
- Water temperature sensor
- LPG injector
- LPG solenoid
- Throttle chamber
- Crankshaft position sensor
- Spark plugs
- Gasoline fuel hose
- PCV valve
- Gasoline injector
- LPG pressure sensor
- Mass air flow sensor
- Ignition coil
- Camshaft position sensor
- Exhaust tube from manifold to catalytic converter
- Gasoline fuel cap