

# Parts Book

PMA 540



# 540

## RUBBER TIRED LOADER

SERIAL NUMBERS **540 -5001** and up



Copyrighted Material  
Intended for CLARK dealers only  
Do not sell or distribute

# PARTS BOOK



## Instructions for Binder Inserts

PMA 540

This sheet includes two styles of binder inserts:

← Insert for earlier vinyl clear window binder  
Cut binder insert on lines indicated and insert in spine of binder. Discard the front cover binder insert.

Insert for later poly binder with half window  
Insert clear insert protection sheet in label holder. Cut binder insert on lines indicated and insert behind insert protection sheet in spine of binder.

 **DRESSER®**

540



 **DRESSER®**

540



 **DRESSER®**

540



- 6 If the parking brake microswitch does not operate correctly, refer to the following adjustment procedures.

## PARKING BRAKE SWITCH ADJUSTMENT

Step 1: Turn key switch "OFF".

Step 2: Remove the pylon access cover.

Step 3: Loosen and remove the hand brake bracket mounting bolt nuts and move hand lever away from pylon for access to switch mounting screws.

Step 4: Loosen the microswitch mounting screws.

Step 5: Move and hold the hand brake lever at a point one-third of the way through its travel from the released position. Move the microswitch until the switch lever makes contact with the actuating stud on hand lever. Then, tighten the switch mounting screws.

See NOTICE, Page 4.

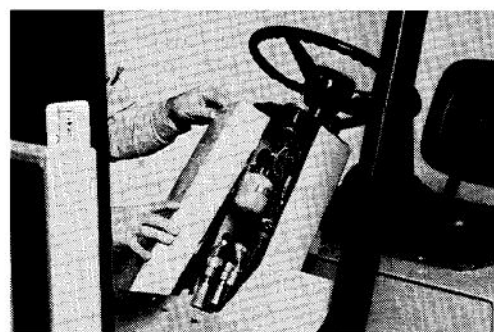

85M510



85M815

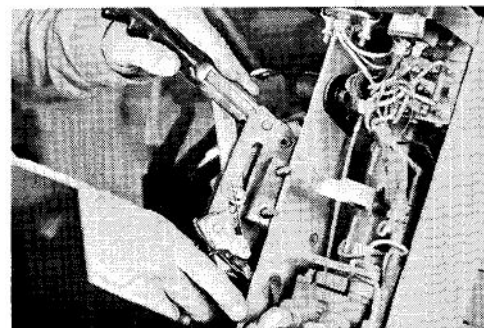

85M816

## GROUP

13

# CLARK

Step 6: Install and tighten the brake lever bracket mounting bolts and nuts.

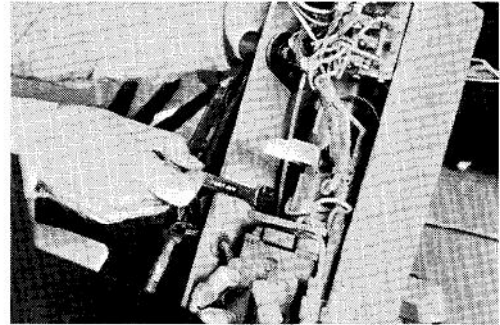

85M815

Step 7: Fully release the parking brake hand lever and check for correct adjustment of the microswitch (see Page 2). Repeat the adjustment procedure, if necessary.

**NOTICE** - The switch body allows only limited movement for adjustment. If additional adjustment is needed, carefully bend the switch lever to contact the stud on hand lever at the correct position.



85M519

Step 8: Install the access cover on pylon.

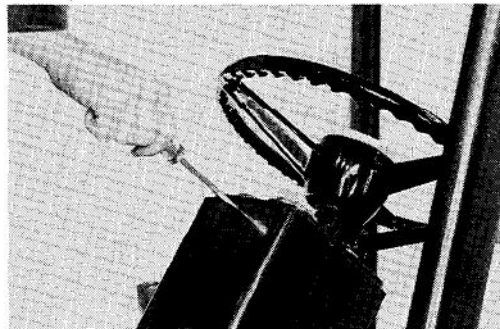

20283

Step 9: Apply the parking brake, tilt the upright fully back to lower drive wheels to the floor, and remove the blocking under the upright.

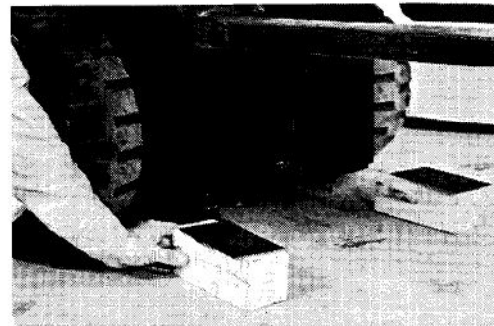

85M741

# **GROUP 13**

## **SECTION 6**

### **ACCELERATOR CONTROL MAINTENANCE AND TROUBLESHOOTING**

EV-100 SCR CONTROL  
SOLID-STATE  
ACCELERATOR SWITCH ASSEMBLY

Refer to Systems Diagnostic Manual, SDM-542,  
for additional information on troubleshooting  
of the accelerator control with the EV-100  
SCR control.

#### **⚠ CAUTION**

BEFORE ANY ADJUSTMENTS, SERVICING, PARTS  
REPLACEMENT OR ANY ACT IS PERFORMED REQUIRING  
PHYSICAL CONTACT WITH WORKING COMPONENTS  
OR WIRING OF THIS COMPONENT:

- RAISE DRIVE WHEELS OFF THE FLOOR,
- DISCONNECT THE BATTERY, AND
- DISCHARGE THE CAPACITOR 1C.

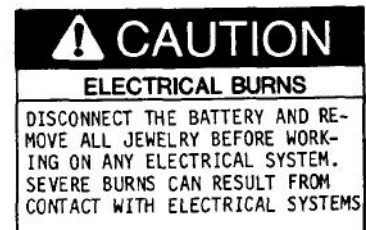

EV-100 SCR CONTROL  
SOLID-STATE  
ACCELERATOR CONTROL (SWITCH) ASSEMBLY

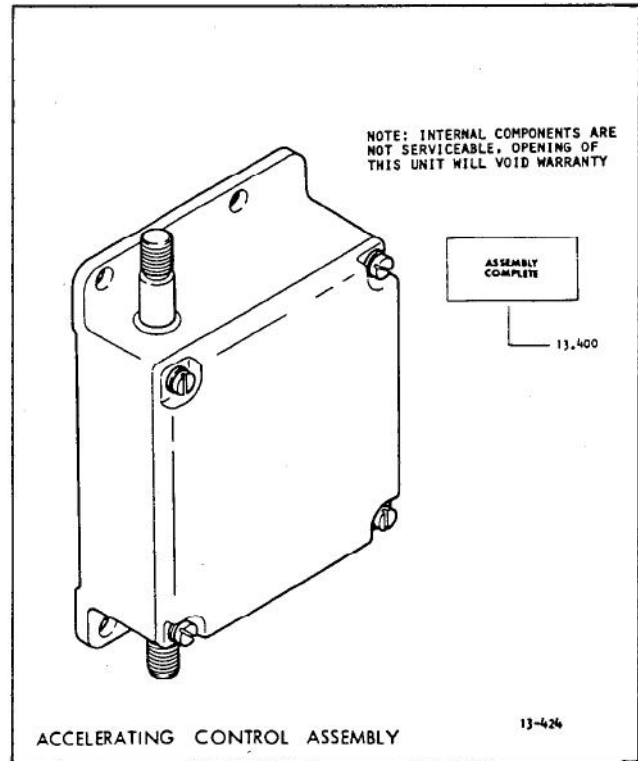
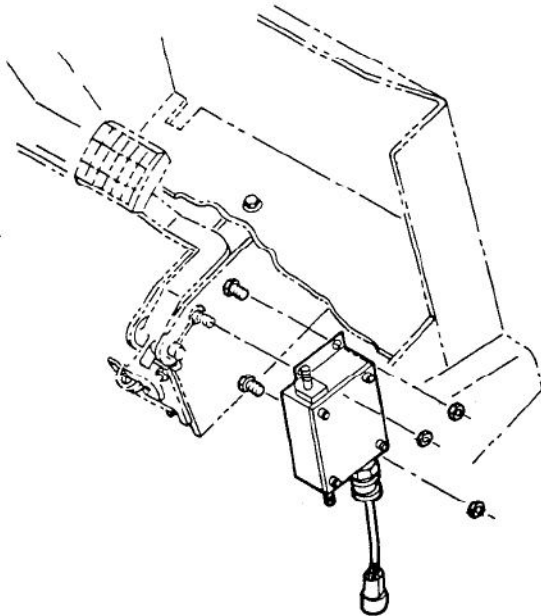

The accelerator control switch assembly contains:

- 1 a switch (IMS start switch) which closes at the beginning of shaft travel to energize the control circuit, and
- 2 a solid-state counter circuit which varies the speed of the truck while in SCR control.

The counter circuit consists of a solid-state infrared light source and a position sensor. As the position sensor moves with respect to the light source, digital signals are generated. These signals are converted to an analog voltage output to provide a linear speed signal to the control.

No parts are adjustable except the start switch, which should require no adjustment under all normal conditions.

Self-lubricating bearings are used eliminating the need for any lubrication. Underwriters' Laboratory Type EE construction, O-ring seal, blind mounting holes, and insulated wire hole grommet all combine to eliminate the need for periodic cleaning.

## Specifications:

IMS start switch should close at [1,9-2,3 mm] .075-.091 in. of shaft travel. SWITCH MUST OPEN BEFORE SHAFT RETURNS TO THE STOP POSITION.

Counter Circuit Voltage Output Curve: Linear.

Nominal voltage output: 3.65 volts @ [0-2,1 mm] 0-.082 in. travel  
0.25 volts @ [13,5-14,0 mm] .53-.55 in. travel

**NOTICE - ATTEMPT TO REMOVE OR REPAIR CIRCUIT CARDS IN THE SWITCH WILL VOID WARRANTY.**

## ACCELERATOR CONTROL CHECKS & TROUBLESHOOTING

Trouble with the accelerator control will normally be investigated in conjunction with troubleshooting of the SCR traction control\*.

There are two basic checks that need to be made to troubleshoot the accelerator control. Check for:

- 1 Correct voltage input to the accelerator control circuit.
- 2 Correct voltage output from accelerator control.

\*Refer to SDM-542, Control Card Voltage Checks, and Troubleshooting Symptom: 1, 2, 5 and 6.

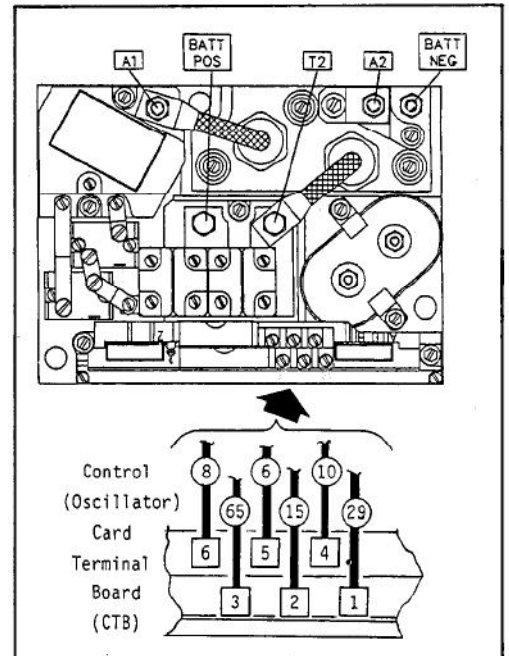

26543

## **CAUTION**

RAISE THE DRIVE WHEELS OFF THE FLOOR BEFORE DOING ANY TROUBLESHOOTING CHECKS.

Refer to GROUP 38, Section 3, Machine Jacking and Blocking.

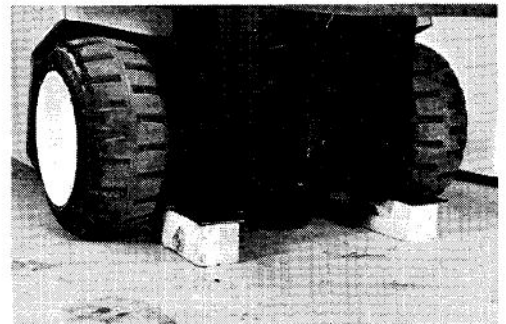

85M743

**Check Voltage Input To Accelerator Control  
Procedure 1:\***

- 1 Connect battery.
- 2 Turn key switch "ON".
- 3 Release hand (parking) brake.
- 4 Connect volt-ohmmeter (V-O-M) red (+) lead to screw terminal TB3 (wire #65) of the control (oscillator) card on SCR control.
- 5 Connect V-O-M black (-) lead to battery negative. (Also see Figure 26543, Page 3.)

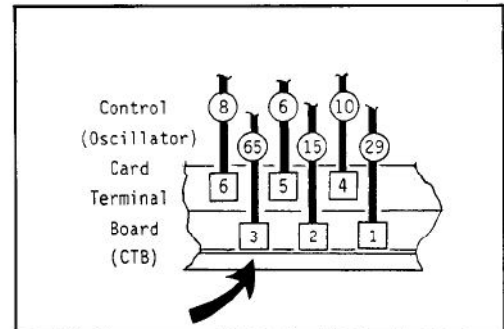

26544

- 6 With the key switch and hand brake switch closed, the V-O-M must read battery volts.

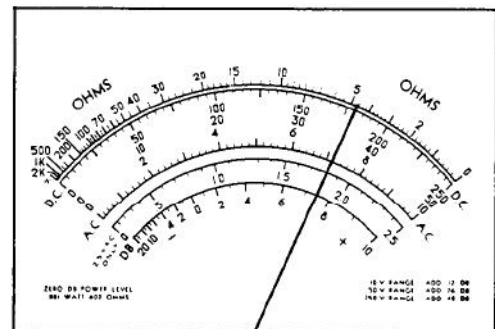

26545

- 7 When either the key switch or hand brake switch are opened, the V-O-M must show 0 volts.

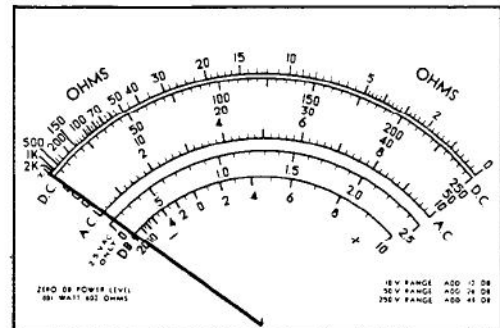

17772

- 8 If the V-O-M measured values are not as given above, check the key switch, hand brake switch, and wiring to the control. Check control fuse (3FU) and continuity of wire #2, 10, 12, and 65. Repair and/or replace, as necessary.

\*Reference SDM-542, Card Voltage Checks, TB3.  
Also Symptom: 1.

### Procedure 2:\*

- 1 Turn key switch "OFF".
- 2 Apply hand brake.
- 3 Accelerator pedal released.
- 4 Connect V-O-M red (+) lead to screw terminal TB2 (wire # 15) of the control card on SCR control.
- 5 Connect V-O-M black (-) lead to battery negative.

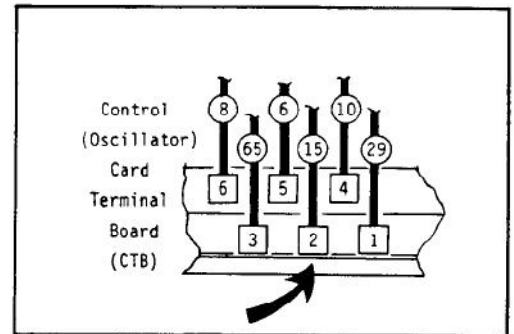

26544

- 6 With the key, hand brake, or IMS switches open, the V-O-M must show 0 volts.

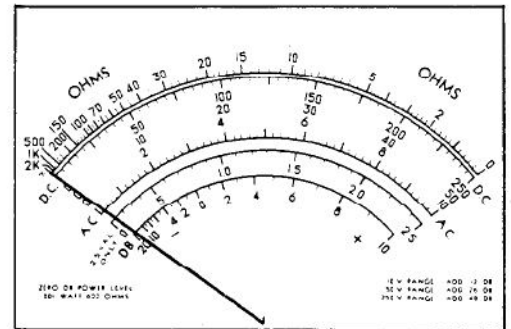

17772

- 7 Turn key switch "ON".
- 8 Release hand brake.
- 9 Push on accelerator pedal slightly to close IMS switch.
- 10 With the key, hand brake, and IMS switches closed, the V-O-M must show battery volts.

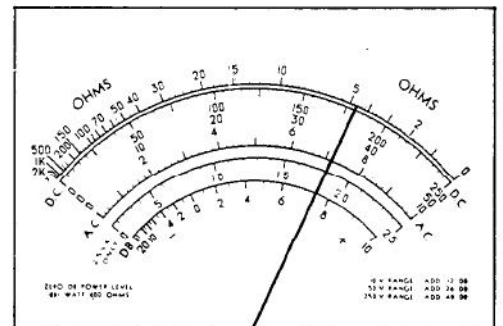

26545

- 11 If the V-O-M measured values are not as given above, check the key, hand brake, and IMS switches. Also, check control fuse (3FU) and wiring to the control, including continuity of wire #15 (see Procedure 1). Repair and/or replace, as necessary.

\*Refer to SDM-542, Card Voltage Check, TB2.  
Also Symptom: 1.

**Check Accelerator Control Voltage Output\***

- 1 Turn key switch "OFF". Disconnect battery.
- 2 Disconnect wire #29 from screw terminal TB1 of the control card on SCR control.
- 3 Connect V-0-M red (+) lead to wire #29 removed from terminal TB1.
- 4 Connect V-0-M black (-) lead to battery negative.
- 5 Connect battery. Turn key switch "ON".
- 6 Release the hand brake.

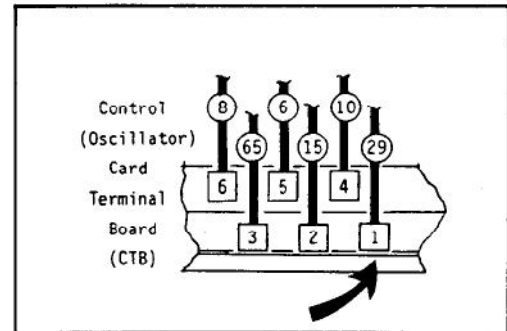

26544

- 7 With key and hand brake switches closed, and accelerator released (or at creep speed position), the V-0-M must show 3 - 4 volts. (3.65 volts nominal rating).

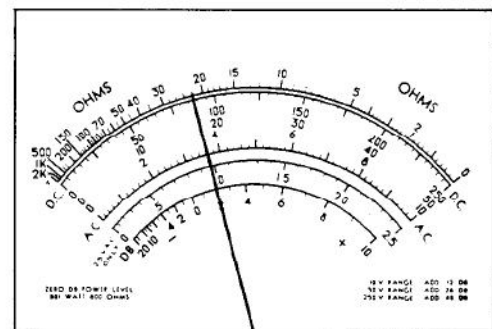

26546

- 8 Measure voltage on wire #29 as accelerator control is moved from creep to top speed. Voltage should change (decrease) from 3 - 4 volts to 0 - .5 volts as accelerator control is moved from creep to top speed.

- 9 Push the accelerator pedal fully down.

With key and hand brake switches closed and accelerator control fully depressed, the voltage must decrease to less than 0.5 volts (0.25 volts nominal rating).

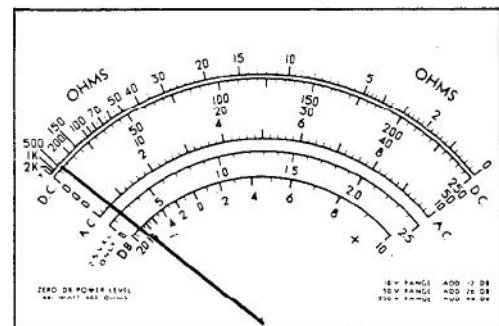

26547

- 10 If the V-0-M does not show the correct voltages as noted above, the accelerator control switch is defective and must be replaced.

- 11 Turn key switch "OFF". Disconnect battery. Reconnect wire #29 to terminal TB1 of control card. Connect battery. Turn key switch "ON". Connect V-0-M to terminal TB1 and battery negative. Measure voltage as accelerator is moved from creep to top speed position. If voltage does not change (decrease) from 3-4 volts to 0-.5 volts, this indicates a defective control (oscillator) card. Refer to SDM-542 for additional checks.

\*Refer to SDM-542, Card Voltage Checks, TB1.  
Also Symptom: 2, 4, 5, and 6.