

SERVICE MANUAL

GTS 20/25/30/33 L ***(PSI 4G64)***

Rated Capacity : 2000 - 3300 Kg

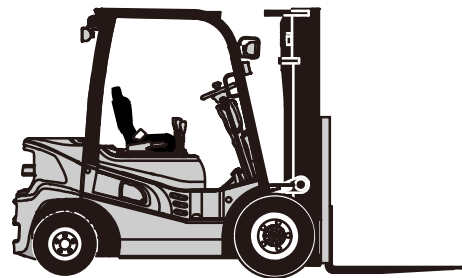

Part No. 8129703
Book No. SM 1024 (Rev 1.7)
Oct. 2019



CLARK MATERIAL HANDLING INTERNATIONAL
215, Ojeong-ro, Bucheon-Si, Gyeonggi-do, Korea
Tel: 82-32-680-6300 [www.clarkmhc.co.kr]

CONTENTS

Group SA. Safe Maintenance

Group PS. Periodic Service

Group 00. Engine

- LPG : PSI 4G64

Group 01. Cooling System

Group 03. Intake and Exhaust System

Group 07. Transmission

Group 13. Electrical System

Group 20. Drive Axle

Group 22. Wheels and Tires

Group 23. Brake System

Group 25. Steering Column and Gear

Group 26. Steer Axle

Group 29. Hydraulic Pump, Sump, and Filters

Group 30. Hydraulic Control Valve/Lift Circuit

Group 32. Tilt Cylinders

Group 34. Upright

Group 38. Counterweight & Chassis

Group 40. Specifications

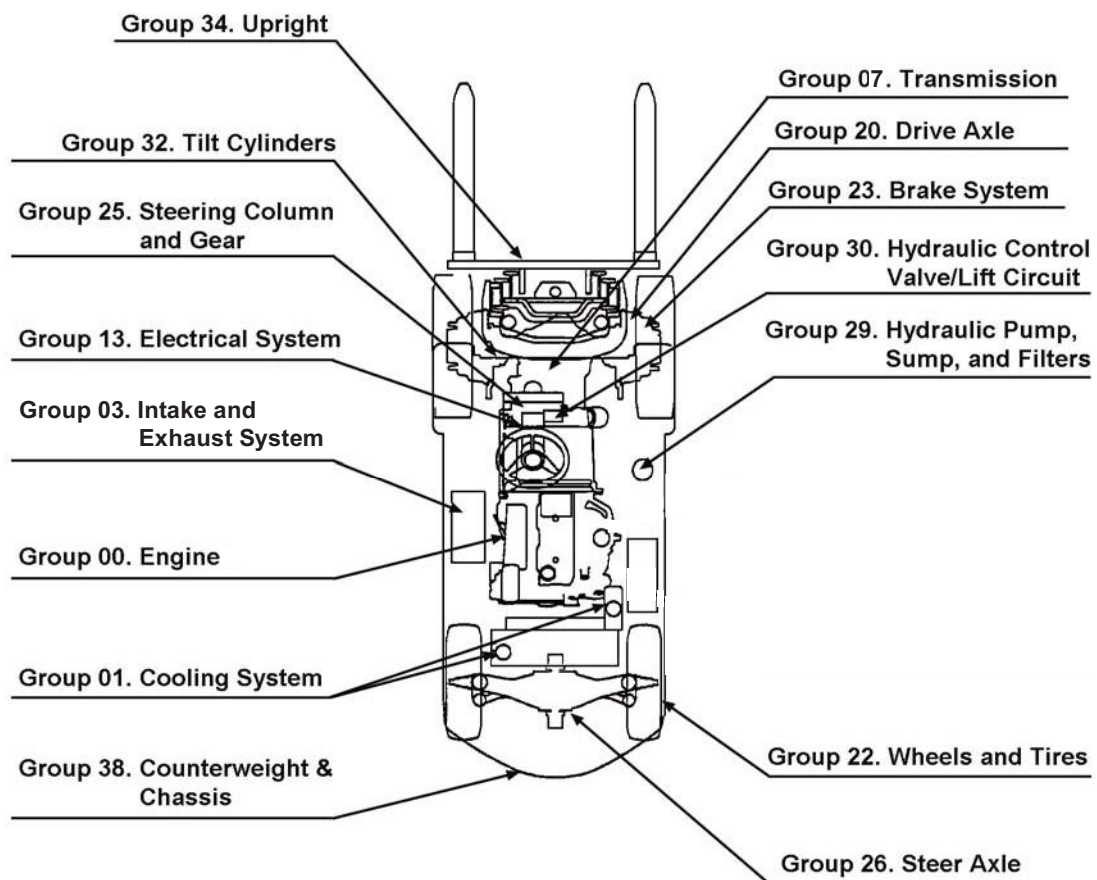

REMOVAL AND INSTALLATION

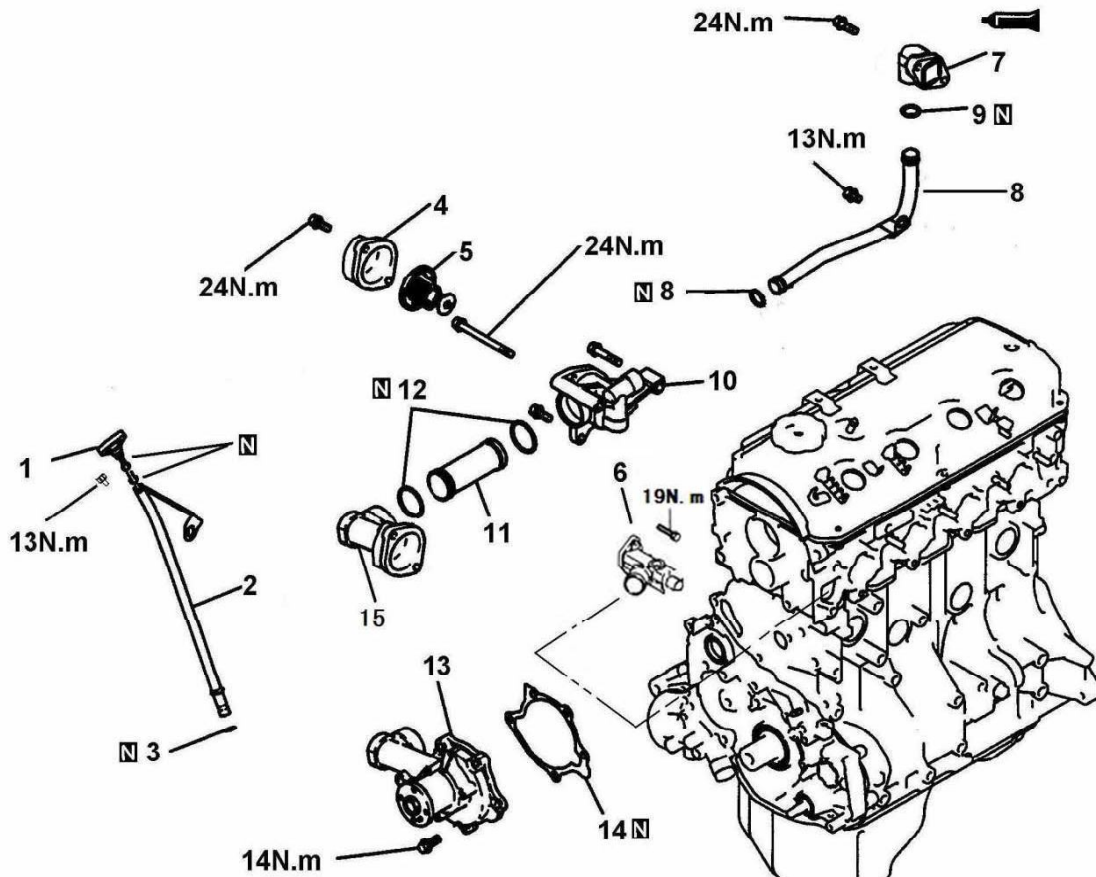

Removal steps

- | | | |
|--------------------------|-------|-------------------------|
| 1. Oil level gauge | >>A<< | 9. O-ring |
| 2. Oil level gauge guide | | 10. Thermostat housing |
| 3. O-ring | | >>A<< |
| 4. Water inlet fitting | | 11. Water inlet pipe |
| >>C<< | | >>A<< |
| 5. Thermostat | | 12. O-ring |
| >>B<< | | 13. Water pump |
| 6. Water outlet fitting | | 14. Water pump gasket |
| 7. By-pass fitting | | 15. Water inlet fitting |
| >>A<< | | |
| 8. Water inlet pipe | | |

INSTALLATION SERVICE POINTS

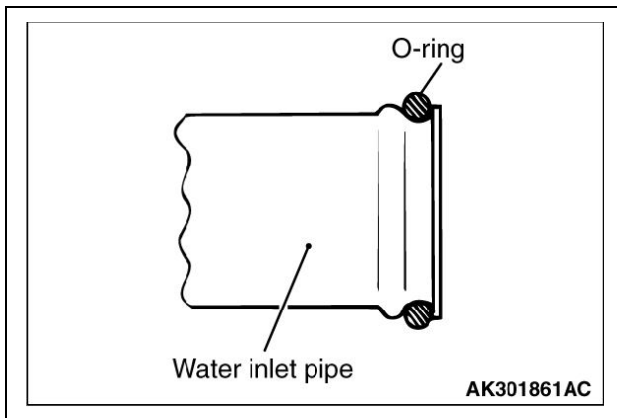

>>A<< WATER INLET PIPE/O-RING INSTALLATION

1. Attach a new O-ring to each end of the water inlet pipe.
2. Wet the O-ring with water.

NOTE

Keep the O-ring free of oil or grease.

>>B<< WATER OUTLET FITTING INSTALLATION

1. Apply a 3 mm diameter bead of FIPG to the indicated surface of the water outlet fitting.
Specified sealant: Permatex Ultra Grey Gasket Maker pt# 82194 or equivalent.
2. Install the housing quickly, (within 15 minutes) while the sealant is wet, and tighten the bolts to the specified torque.

NOTE

After installation, keep the sealed area away from the coolant for approximately one hour.

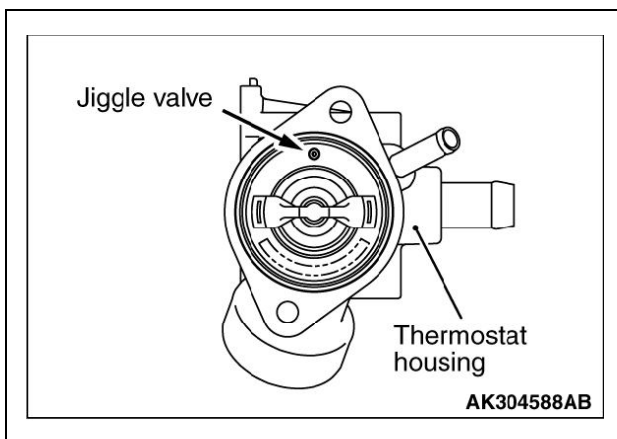

>>C<< THERMOSTAT INSTALLATION

1. Check that the rubber ring is undamaged and seated correctly in the thermostat flange.
2. Install the thermostat as shown in the illustration. The jiggle valve must be at the uppermost position.

REMOVAL AND INSTALLATION

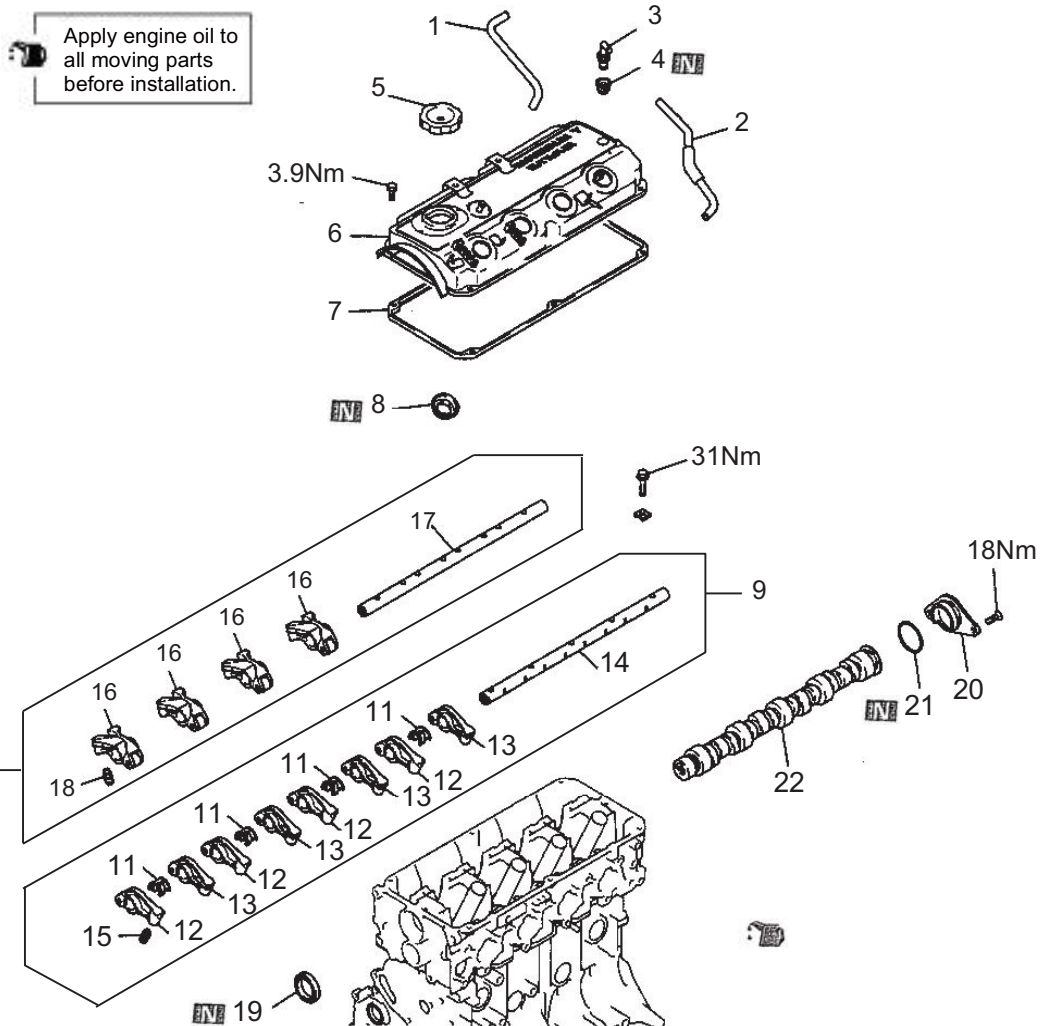

Removal steps

- | | |
|--|-------------------------------------|
| 1. Breather hose | 12. Rocker arm "A" |
| 2. PCV hose | 13. Rocker arm "B" |
| 3. PCV valve | 14. Rocker arm shaft (Intake side) |
| 4. PCV valve gasket | >>B<< 15. Lash adjuster |
| 5. Oil filler cap | 16. Rocker arm "C" |
| 6. Rocker cover | 17. Rocker arm shaft (Exhaust side) |
| 7. Rocker cover gasket | >>B<< 18. Lash adjuster |
| 8. Oil seal | >>A<< 19. Oil seal |
| <<A>> >>C<< 9. Rocker arms and rocker arm shaft | 20. Thrust case |
| <<A>> >>C<< 10. Rocker arms and rocker arm shaft | 21. O-ring |
| >>C<< 11. Rocker arm shaft ring | 22. Camshaft |

REMOVAL SERVICE POINT

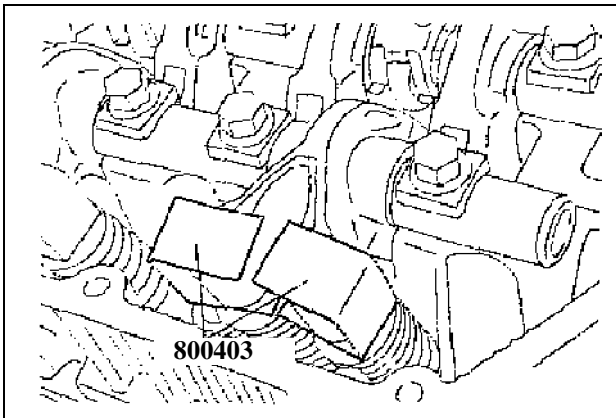

<<A>> ROCKER ARMS AND ROCKER ARM SHAFT REMOVAL

1. Before removing rocker arms and shafts assembly install the special tool as illustrated prevent the adjusters from dropping.

INSPECTION

CAMSHAFT

Measure the cam height. If it is below the limit, replace the camshaft.

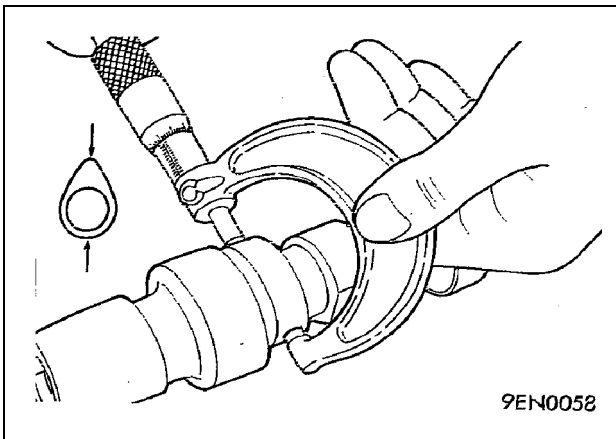

	Standard value	Minimum limit
Intake	37.39mm	36.89mm
Exhaust	36.83mm	36.33mm

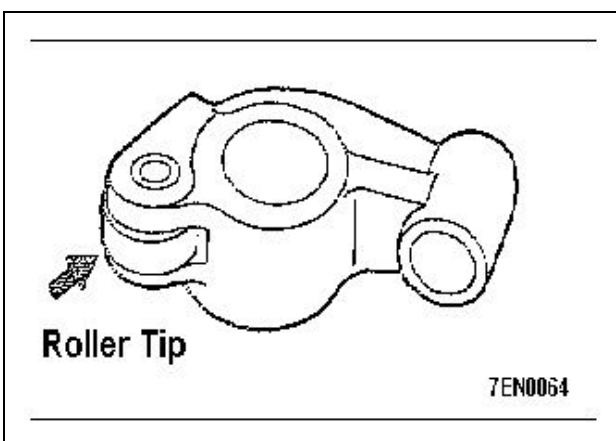

ROCKER ARM

1. Check the roller or slipper surface. If any dents, damage or seizure is evident, replace the rocker arm.
2. Check the roller for smooth rotation. If it does not rotate smoothly, or if looseness is evident, replace the rocker arm.
3. Check the inside diameter. If damage or seizure is evident, replace the rocker arm.

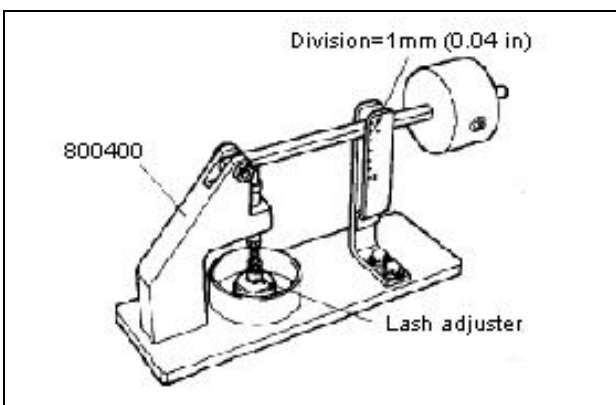
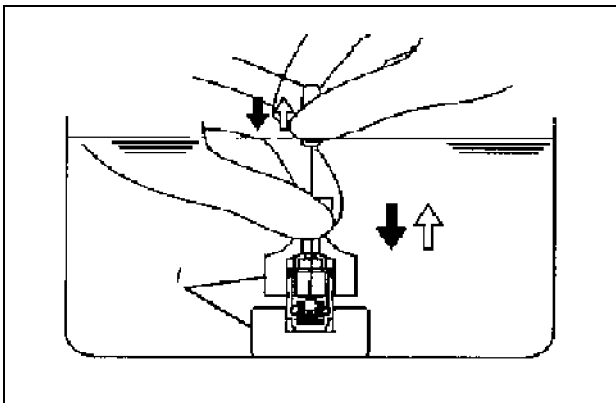
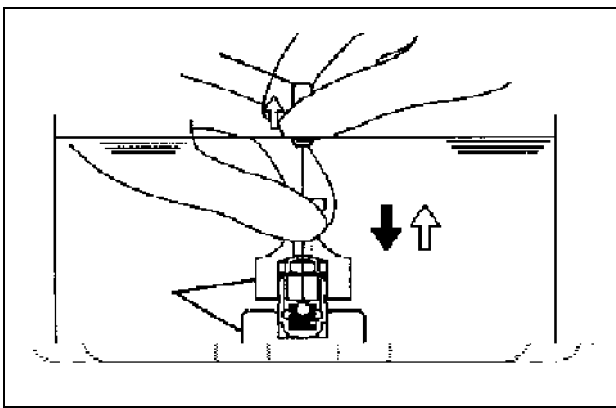
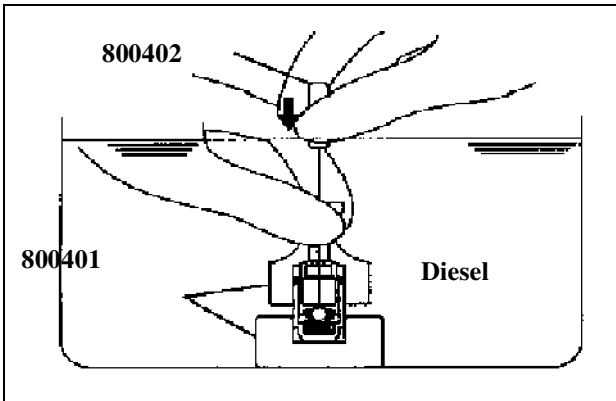

LASH ADJUSTER LEAK DOWN TEST

NOTE

The lash adjuster is a precision part. Keep it free from dust and other foreign matter. Do not disassemble lash adjusters. When cleaning lash adjusters, use clean diesel fuel only.

1. Immerse the lash adjuster in clean diesel fuel.
2. While lightly pushing down the inner steel ball using the special tool, Air Bleed Wire, move the plunger up and down four or five times to bleed air. Use of the retainer (special tool) helps facilitate the rocker arm mounted type lash adjuster.
3. Remove the wire and press the plunger. If the plunger is hard to be pushed in, the lash adjuster is normal. If the plunger can be pushed in all the way readily, bleed the lash adjuster again and test again. If the plunger is still loose, replace the lash adjuster.

NOTE

Upon completion of air bleeding, hold the lash adjuster upright to prevent inside diesel fuel from spilling.

4. After air bleeding, set the lash adjuster on the special tool (Leak down tester 800400).
5. After the plunger has gone down somewhat (0.2-0.5 mm), the measured time is out of the specification.

Standard value:

4-20 seconds/1 mm (Diesel fuel at 15-20 °C)

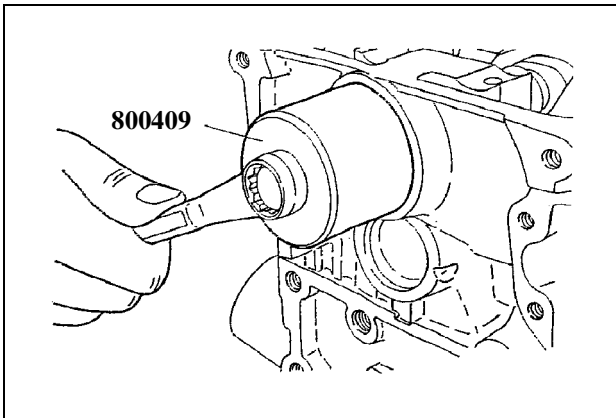
INSTALLATION SERVICE POINTS**>>A<< CAMSHAFT SEAL INSTALLATION****>>B<< LASH ADJUSTER INSTALLATION**

1. Immerse the lash adjuster in clean diesel fuel.
2. Using the special tool (air bleed wire), move the plunger up and down 4 or 5 times while pushing down lightly on the check ball in order to bleed out the air.

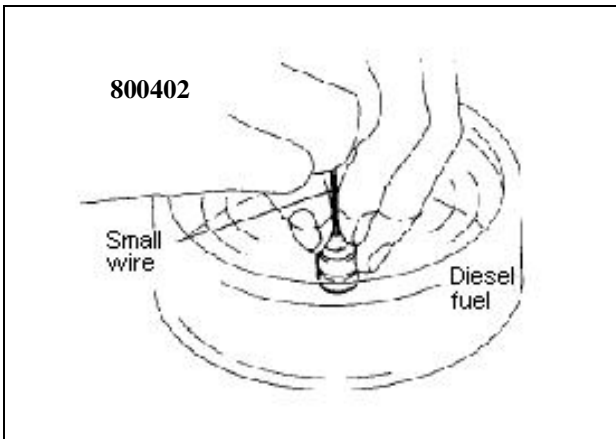

3. Insert the lash adjuster to the rocker arm, being careful not to spill the diesel fuel. Then use the special tool to prevent the adjuster from falling while installing it.

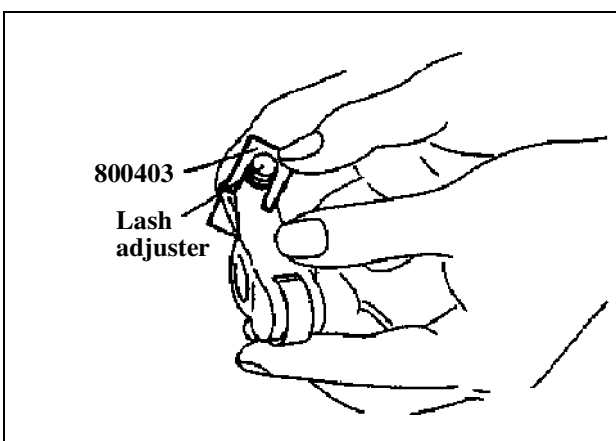

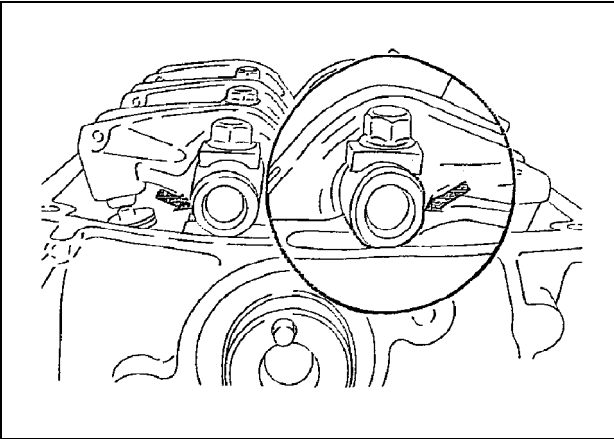
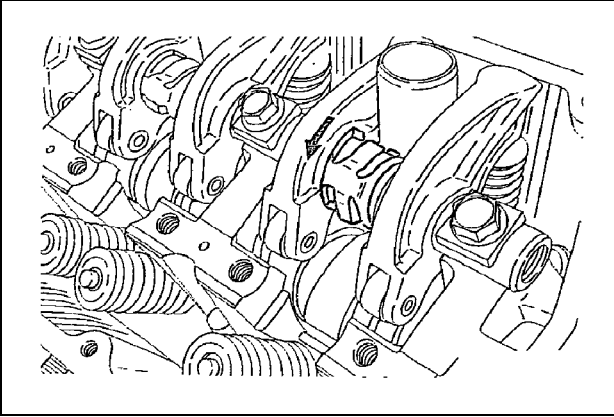
**>>C<< ROCKER SHAFT SPRING, ROCKER ARM AND ROCKER SHAFT INSTALLATION**

1. Temporarily tighten the rocker shaft on the inlet valve side with bolt so that all rocker arms do not push the valves.
2. Fit the rocker shaft spring from the above and position it so that it is right angles the spark plug guide.

NOTE

Install the rocker shaft springs before installation of the exhaust side rocker arms and shaft.

3. Remove the special tool used to hold the lash adjuster.
4. Make sure that the notch in the rocker shaft is directed as shown in the illustration.

NOTE

THE NOTCH SHOWN SHOULD ALWAYS FACE THE VALVE TIP. THE NOTCH/OIL PASSAGE ALLOWS FOR THE OIL TO TRAVEL TO THE VALVE LASH ADJUSTERS

Section 5

Cylinder Head and Valves



Cassification of Service Points

Key service points, service standards, and instructions for using special tools are collated as service points and explained in detail.

- <<A>> : Outward-pointing brackets denote removal service points or disassembly service points.
- >>A<< : Inward-pointing brackets denote installation service points or reassembly service points.

Lubricant and Sealant Symbols

Every location where a lubricant or sealant must be applied or added is indicated using a relevant symbol in the component part drawing and/or on the page after the component part drawing.

	Grease		Sealant or form-in-place gasket (FIPG)
	Brake fluid		Engine oil or gear oil