

# SERVICE MANUAL

---

## *C 40/45/50s/55s L*

*(PSI 4X Engine Truck)*

Capacity : 4000-5500 kg

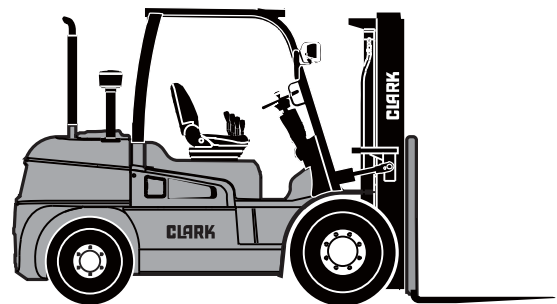

Part No. 8139175

Book No. SM 1056 (Rev 1.2)

Nov. 2019



**CLARK MATERIAL HANDLING INTERNATIONAL**

215, Ojeong-ro, Bucheon-Si, Gyeonggi-do, Korea

Tel: 82-32-680-6300 [ [www.clarkmhc.co.kr](http://www.clarkmhc.co.kr) ]

**COPYRIGHT WARNING!**

Information intended for authorized CLARK dealers only. Do not sell or distribute.

# CONTENTS

**Group SA.** Safe Maintenance

**Group PS.** Periodic Service

**Group 00.** Engine (PSI 4X 4.3)

**Group 01.** Engine Cooling System

**Group 03.** Intake and Exhaust System

**Group 06.** Transmission

**Group 13.** Electrical system

**Group 20.** Drive Axle

**Group 22.** Wheels and Tires

**Group 23.** Brake System

**Group 25.** Steering Column and Gear

**Group 26.** Steer Axle

**Group 29.** Hydraulic Sump, Filters, and Pump

**Group 30.** Hydraulic Control Valve

**Group 32.** Tilt Cylinders

**Group 34.** Uprights

**Group 38.** Counterweight and Chassis

**Group 40.** Specifications

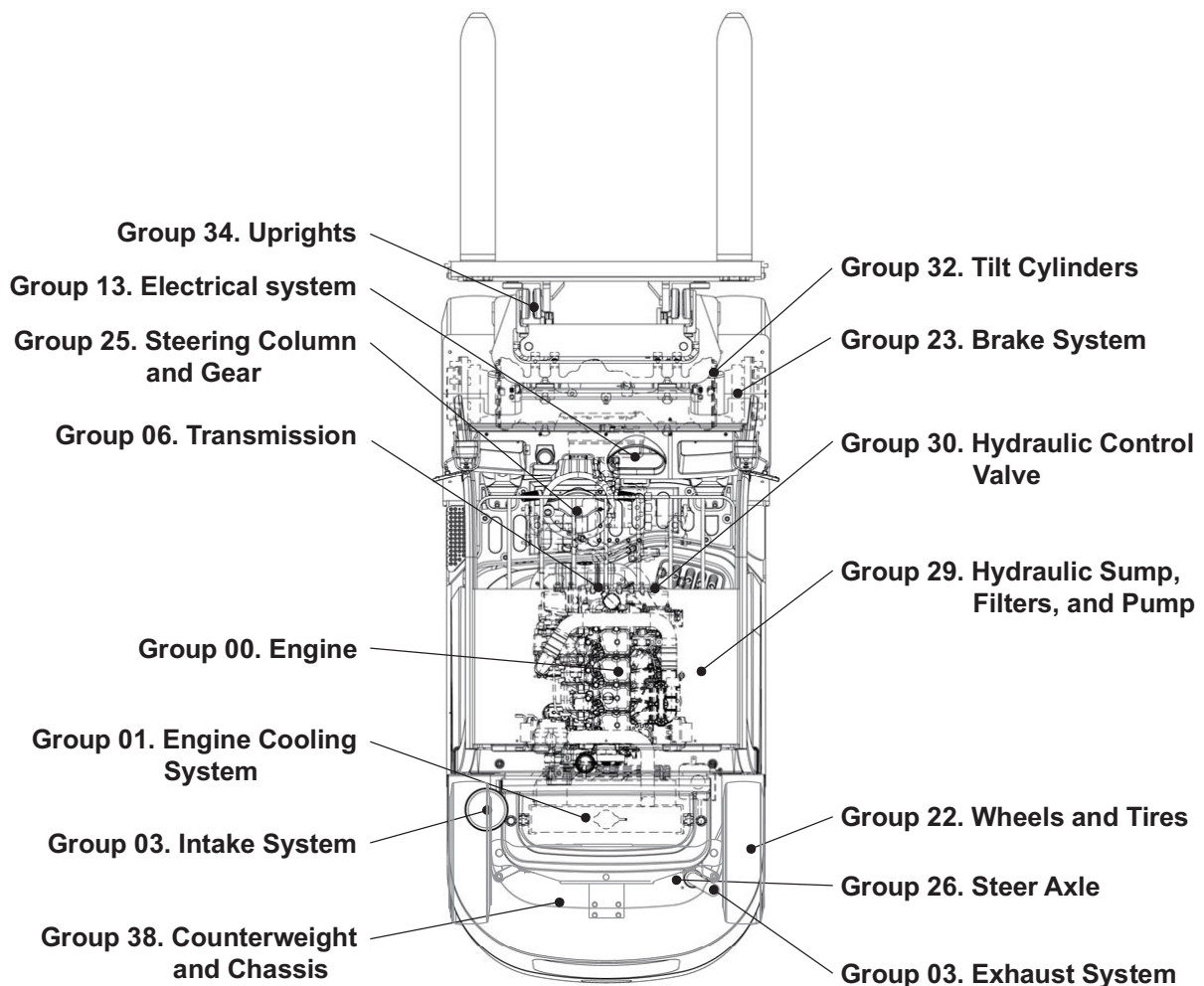

### Blocking the Upright In Raised Position

This procedure is used to safely provide clearance for access from the front of truck to components on or near the drive axle. Illustrations show upright with forks removed however, fork removal is not necessary

1. Park truck safely as described in "Safe Parking."
2. Put blocks in front of and behind drive wheels.
3. Put wooden support blocks conveniently near upright rails before raising the upright. Use two 100 x 100 mm (4 x 4 in) hardwood blocks or equal, of about 300 x 300 mm (12 in) and 600 x 600 mm (24 in) length.

#### NOTE

**For standard uprights, block may need length cut to suit. For triple stage uprights, the carriage may be blocked up, as shown.**

4. Start engine and raise the upright carriage.
5. Hold the taller block against inner rail and lower the upright until carriage rests on block.

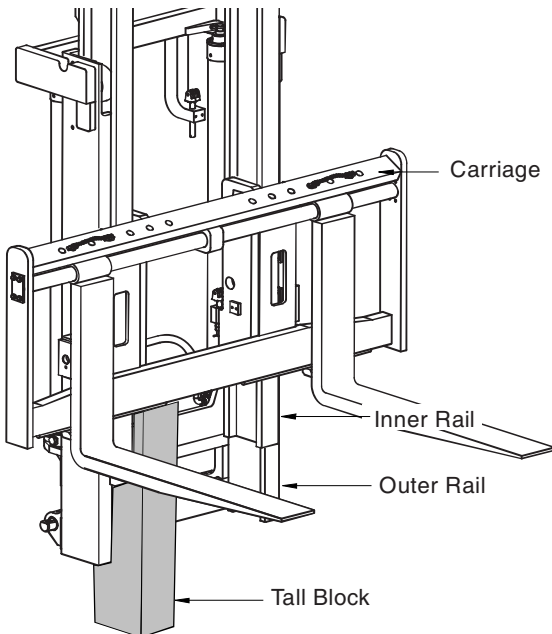

6. Hold the shorter block against the outer rail and lower the upright until inner rail rests on the block.

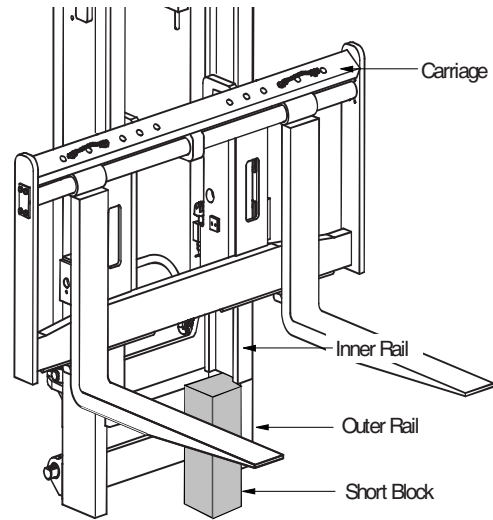

7. Reverse the procedure to remove blocking.

### Raising Rear of Truck

The truck may be raised at the rear by jacking and blocking under the center of the frame member at either the front or rear steer axle mounting, or under the center section of the steer axle.

Refer to truck data plate for truck weights.



#### WARNING

**An incorrectly installed counterweight can move or fall unexpectedly. Never lift or block a truck using the counterweight. Failure to follow procedures outlined in this manual can result in injury or death.**

1. Park truck safely as described in "Safe Parking." Put blocks at front and rear of drive wheels.

- Put a floor jack under the steer axle mounting frame member, centered between the two wheels.

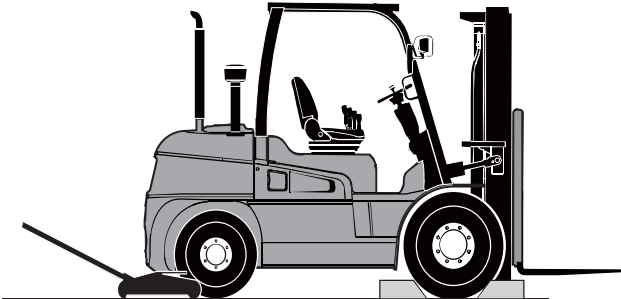

### WARNING

Never lift the truck by the counterweight.

### NOTE

If there is insufficient clearance under frame for your jack, the truck may first be driven onto shims, such as 25 x 150 x 300 mm (1 x 6 x 12 in) pieces of board, to increase the truck frame underclearance.

- Raise the truck only as high as necessary to perform the maintenance work.
- Put blocks at both sides of the truck, fully under the frame main side structure. Put the blocks in front of but close to the counterweight and steer wheels for best truck stability.

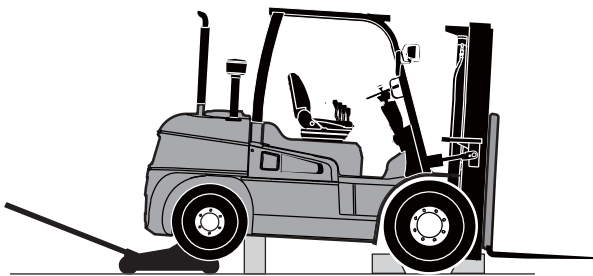

Put an equal amount of blocks under each side of the truck to provide a level working position.

- Lower the truck onto the blocks and remove the jack.



### CAUTION

Before performing any maintenance work, check the truck for stable condition on the blocking.

- When maintenance work is completed, lower the rear of truck to the floor by reversing the above procedure and lowering each side of the truck 50 mm (2 in) at a time:

- Put jack under frame and raise truck.
- Carefully remove blocks and lower truck.
- Remove jack and blocks from drive wheels.

## Raising Entire Truck

Refer to truck data plate for truck weights.

- Park truck safely as described in "Safe Parking." Lower upright fully.
- If necessary, drive truck onto boards to increase underclearance.



### WARNING

**SIDE-TO-SIDE TIPOVER.** When jacking side of truck, be sure upright is lowered fully and do not raise one side of the truck more than about 50 mm (2 in) higher than the other, to avoid tipping truck over laterally.

**END-TO-END TIPOVER.** If the upright and transaxle are removed while the truck is blocked up, the truck will tip backwards due to the heavy counterweight. Both upright and counterweight must be removed before attempting to raise the truck for transaxle removal. The back of the truck must be supported by blocking under the steer axle to prevent movement.

The reverse is also true. If the counterweight is removed while the truck is up on blocks, the weight of the upright and transaxle will cause the truck to tip on the front blocks and fall forward.

- Put the jack under side frame near the center of the truck.

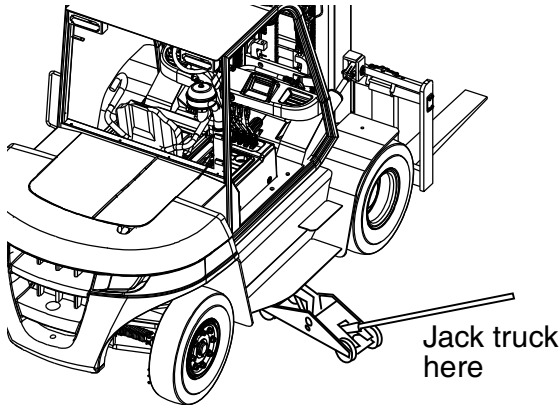

### IMPORTANT

Be sure to put the jack squarely and fully under the main side structure of the frame. Do not put the jack under the outer covers which enclose the fuel and hydraulic sump tanks.

- Carefully raise the truck one side at a time, only as high as necessary to do the maintenance work and not more than a maximum of 150 mm (6 in) total.
- Put blocks under the side frame, at each side of the jack. Spread the blocks close to the steer and drive wheels for maximum stability.

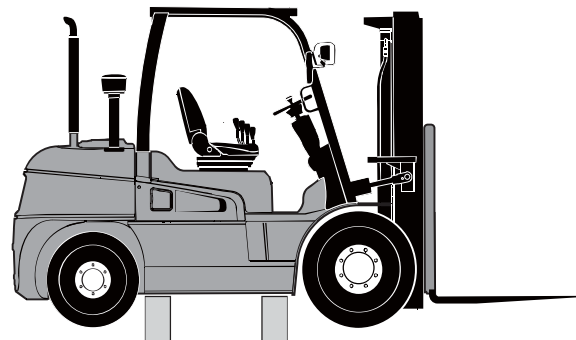

- If using one jack, lower the truck onto the blocks and move the jack to the opposite side. Repeat the lifting procedure.
- Put the same size blocks under each side of the truck so it will be level.



### CAUTION

Before performing any maintenance work, check the truck for stable condition on the blocking.

- When maintenance work is completed, lower the entire truck to the floor by reversing the lifting procedure. Lower the truck one side at a time, while carefully removing the blocks. Check to be sure no tools or equipment are under the truck or wheels.

### NOTE

Depending on jack height, shims under the tires may be needed for clearance to allow removal of jack.

## Shipping Tie-Down Instructions

- Front of Truck
  - With Upright and Carriage Installed
    - Lower the carriage fully.
    - Put a tie down (e.g., chain) between the carriage fork bars.

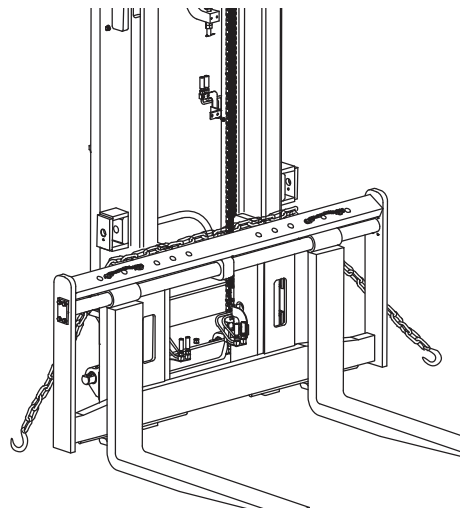

- Without an Upright and Carriage Installed
    - Put a chain across the truck floor plate. Protect truck from chain damage by using covered chain or protective material under the chain at contact points.
- Rear of Truck
    - Attach the tie down to pocket in bottom of counterweight.

## Section 3

### Towing

If your truck is disabled but can be moved freely on its own wheels without further damage, use the following procedures to tow the truck safely to a repair area.

#### **WARNING**

**It is important for your safety and to the care of your lift truck to use the proper equipment and carefully follow these recommendations for safe towing.**

**Do not tow a lift truck if there is a problem with the brakes or tires, or if the steering cannot be operated.**

**Do not tow the disabled truck up or down ramps or steep inclines.**

**Do not attempt to tow the disabled truck if traction or weather conditions are poor.**

1. Be sure to apply the parking brake or block the drive wheels on the disabled truck while working around it.
2. When possible, raise the carriage (forks) on the disabled truck 300 mm (12 in) from the floor or ground. Secure the carriage on the upright with a chain.
3. Use a truck for towing that is of equal or larger capacity than the disabled truck. Carry a partial load on the tow truck for improved traction.

4. Check that the counterweight bolts on both trucks are in place and properly torqued to 440-490 N·m (325-361 ft-lb). These bolts are made of special, high-tensile steel and are not commercially available. When necessary, replace these bolts only with a genuine CLARK replacement part.
5. Use an approved, solid metal tow bar with towing couplers that connect to the towing pins in the counterweights.

#### **NOTE**

**DOT-approved towing equipment is available from your CLARK dealer.**

6. Release the parking brake on the towed vehicle. Place directional control lever in neutral.
7. Tow the disabled truck backwards. An operator must be on the disabled truck.

#### **CAUTION**

**The power steering will not operate on the disabled truck when the engine is not running. The steering handwheel will be difficult to turn.**

8. Tow the truck slowly. Careful towing is necessary to prevent injury to personnel or damage to the disabled truck. The truck should be towed at a speed of less than 8 kph (5 mph, or a moderate walking speed) with a driver in place and steering the disabled truck.

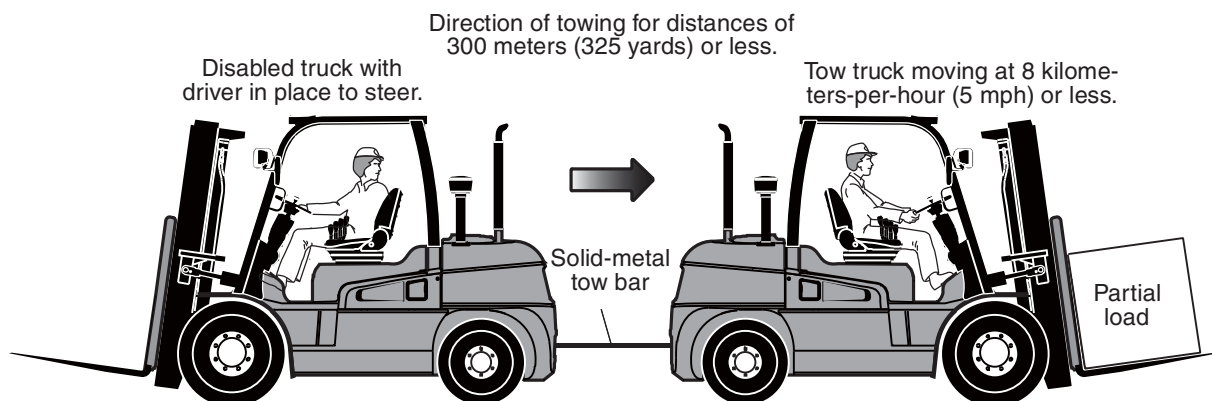

**GROUP PS**

**PERIODIC SERVICE**

**Maintenance Schedules ..... Section 1**

**The Planned Maintenance Program ..... Section 2**

## Section 1

### Maintenance Schedules

#### “Periodic Service” and “Planned Maintenance”

The term “periodic service” includes all maintenance tasks that should be performed on a regularly scheduled basis.

The term “Planned Maintenance” indicates a formalized program of basic inspections, adjustments, and lubrications that the CLARK service organization provides customers at a prescribed interval. The recommended basic “Planned Maintenance” procedure is given in Section 2 of this Group.

The current Section, “Maintenance Schedules,” specifies all maintenance tasks—including Planned Maintenance tasks—that should be performed periodically, and suggests intervals at which they should be performed.

#### Determining Maintenance Intervals

Time intervals on the charts on the next four pages and elsewhere in this manual relate to truck operating hours as recorded on the hourmeter, and are based on experience CLARK has found to be convenient and suitable under normal operation. Standard operating condition classifications are:

##### Normal Operation:

- Eight-hour material handling, mostly in buildings or in clean, open air on clean, paved surfaces.

##### Severe Operation:

- Prolonged operating hours or constant usage.

##### Extreme Operation:

- In sandy or dusty locations, such as cement plants, lumber mills, and coal dust or stone crushing sites.
- High-temperature locations, such as steel mills and foundries.
- Sudden temperature changes, such as constant trips from buildings into the open air, or in refrigeration plants.

#### **IMPORTANT**

**MAINTENANCE INTERVALS.** If the lift truck is used in severe or extreme operating conditions, the maintenance intervals should be shortened accordingly.

Since the operating environments of lift trucks vary widely, the above descriptions are highly generalized and should be applied as actual conditions dictate.

### Service Chart / Lubrication Points

This decal is a basic guide to periodic maintenance intervals and tasks. A more detailed chart is supplied on the next page.

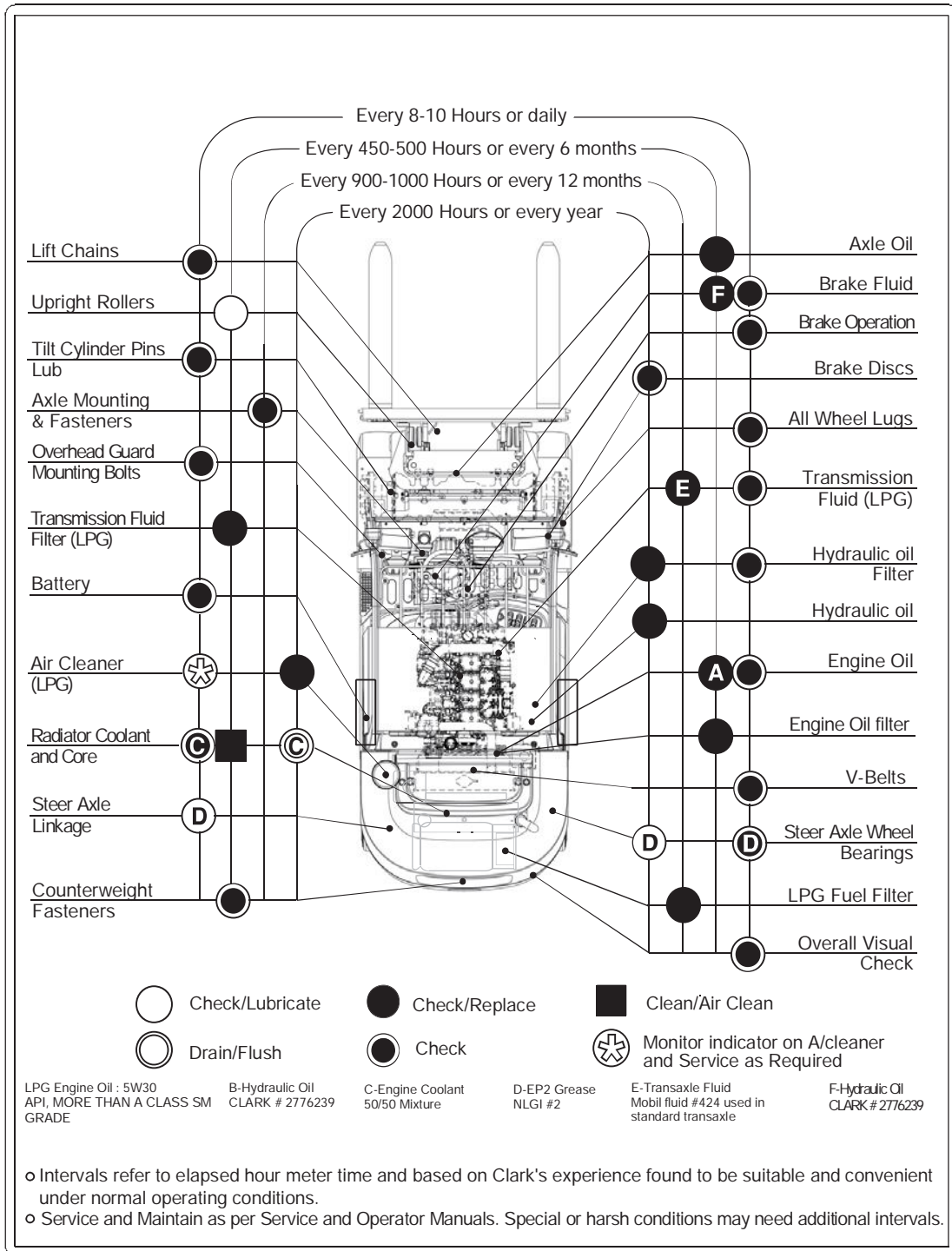

### Recommended Periodic Service Schedule

This chart lists maintenance tasks that should be done periodically, the suggested time intervals, and the service manual Group in which the task is covered.

Apply as appropriate for LPG trucks. Refer to Operator's Manual for **Daily Checks**.

TASKS	Every 8-10 Hours (or daily)	Every 450-500 Hours (or 6 months)	Every 900-1000 Hours (or 12 months)	Every 2000 Hours (or 1 year)
<i>Group PS - Periodic Maintenance</i>				
Perform Planned Maintenance inspections, lubrications, and adjustments		•		
<i>Group 00 - Engine</i>				
Exhaust smoke from gas engine - inspect (blue-oil ; black-fuel)		•		
Idle/governed rpm - check/adjust		•		
Mounts/brackets - inspect/tighten	•			
Oil change - drain/fill		•		
Oil filter cap & seal - clean/check		•		
Oil filter - replace		•		
Oil level/condition - check	•			
Stall rpm - check		•		
Tune up - determine if needed by stall check and/or functional test		•		
Carburetor idle/air - check/adjust		•		
CO level - check/adjust				•
Filler cap/screen - clean/inspect		•		
Fuel filter, lpg - replace			•	
LPG lock-off valve filter - inspect/replace				•
LPG tank mounting/guard - inspect		•		
LPG tank shut-off valve - inspect/test		•		
LPG vaporizer/regulator/hoses - inspect		•		
Throttle linkage - check/adjust		•		
Distributor cap/rotor - inspect		•		
Electronic ignition - test				•
Ignition timing - check/adjust		•		
Ignition wiring - inspect		•		
Neutral start - check		•		
Parking brake interlock - check		•		
Spark plugs - regap/replace				•
Starter motor - inspect/test				•
Starter solenoid - inspect/test				•
<i>Group 01 - Cooling System</i>				
Coolant level/condition - check/sample		•		