

# SERVICE MANUAL

---

## *CGC 40/50/55/60/70* *(PSI 4X Engine Truck)*

Capacity : 4000-7000 kg



Part No. 8139177  
Book No. SM 1058 (Rev 1.2)  
Aug. 2018



---

**CLARK MATERIAL HANDLING INTERNATIONAL**  
215, Ojeong-ro, Bucheon-Si, Gyeonggi-do, Korea  
Tel: 82-32-680-6300 [ [www.clarkmhc.co.kr](http://www.clarkmhc.co.kr) ]

# CONTENTS

## Group Index

<b>Group SA.</b> Safe Maintenance	<b>Group 22.</b> Wheels and Tires
<b>Group PS.</b> Periodic Service	<b>Group 23.</b> Brake System
<b>Group 00.</b> Engine (PSI 4X 4.3 - Tier4)	<b>Group 25.</b> Steering Column and Gear
<b>Group 01.</b> Cooling System	<b>Group 26.</b> Steer Axle
<b>Group 03.</b> Air Intake and Exhaust System	<b>Group 29.</b> Hydraulic Pump, Sump, and Filters
<b>Group 06.</b> Transaxle	<b>Group 30.</b> Hydraulic Control Valve/Lift Circuit
<b>Group 12.</b> Ignition System	<b>Group 32.</b> Tilt Cylinders
<b>Group 13.</b> Instrument Pod	<b>Group 34.</b> Uprights
<b>Group 14.</b> Electrical system	<b>Group 38.</b> Counterweight, Sheet Metal, & Chassis
<b>Group 20.</b> Drive Axle	<b>Group 40.</b> Specifications

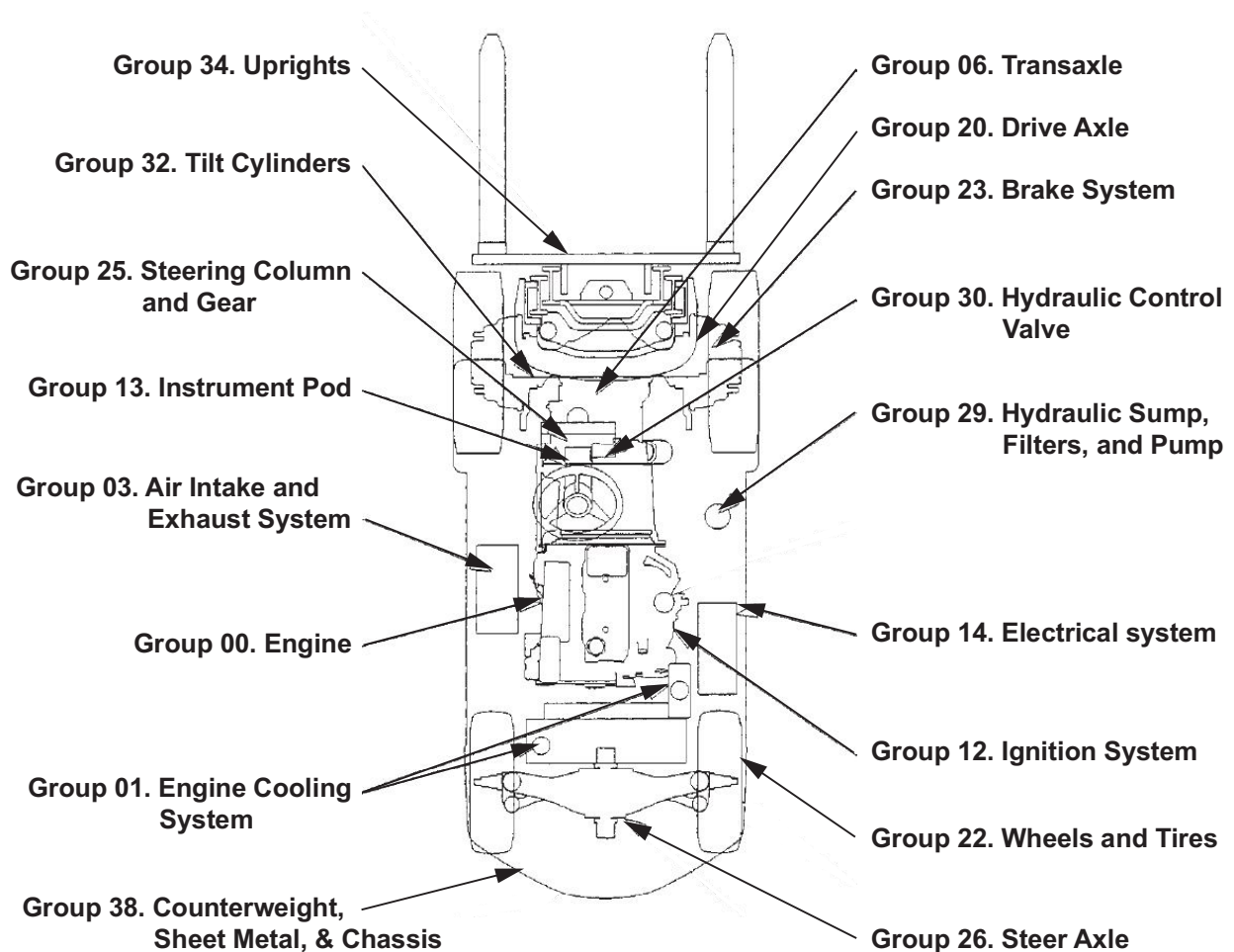

**GROUP SA**

**SAFE MAINTENANCE**

**Safety ..... Section 1**

**Lifting, Jacking, and Blocking the Truck ..... Section 2**

**Towing ..... Section 3**

## Section 1

### Safety

#### Safety Signs and Messages

Safety signs and messages in this manual and on the lift truck provide instructions and identify specific areas where potential hazards exist and special precautions should be taken. Be sure you know and understand the meaning of these instructions, signs, and messages. Damage to the truck, death, or serious injury to you or other persons may result if these messages are not followed.

##### NOTE

**This message is used when special information, instructions or identification is required relating to procedures, equipment, tools, pressures, capacities, and other special data.**

##### IMPORTANT

**This message is used when special precautions should be taken to ensure a correct action or to avoid damage to, or malfunction of, the truck or a component.**



##### CAUTION

**This message is used as a reminder of safety hazards that can result in personal injury if proper precautions are not taken.**



##### WARNING

**This message is used when a hazard exists that can result in injury or death if proper precautions are not taken.**



##### DANGER

**This message is used when an extreme hazard exists that can result in injury or death or serious injury if proper precautions are not taken.**

The above terms have been adopted by CLARK. The same terms may be used in different context in service literature supplied directly or indirectly by vendors of truck components.

#### Safe Maintenance Practices

The following instructions have been prepared from current industry and government safety standards applicable to industrial truck operation and maintenance. These recommended procedures specify conditions, methods, and accepted practices that aid in the safe maintenance of industrial trucks. They are listed here for the reference and safety of all workers during maintenance operations. Carefully read and understand these instructions and the specific maintenance procedures before attempting to do any repair work.

When in doubt of any maintenance procedure, please contact your local CLARK dealer.

1. Powered industrial trucks can become hazardous if maintenance is neglected. Therefore, suitable maintenance facilities, trained personnel, and procedures must be provided.
2. Maintenance and inspection of all powered industrial trucks shall be done in conformance with the manufacturer's recommendations.
3. A scheduled planned maintenance, lubrication, and inspection program shall be followed.
4. Only trained and authorized personnel shall be permitted to maintain, repair, adjust, and inspect industrial trucks. Work should be performed in accordance with the manufacturer's specifications.
5. Properly ventilate work area, vent exhaust fumes, and keep shop clean and floor dry.
6. Avoid fire hazards and have fire protection equipment present in the work area. Do not use an open flame to check for level or leakage of fuel, electrolyte, oil, or coolant. Do not use open pans of fuel or flammable cleaning fluids for cleaning parts.
7. Before starting work on truck:
  - a. Raise drive wheels off of floor and use blocks or other positive truck positioning devices.
  - b. Disconnect battery before working on the electrical system.
8. Before working on engine fuel system of gasoline- or diesel-powered trucks, be sure the fuel shut-off valve is closed.

9. Operation of the truck to check performance must be conducted in an authorized, safe, clear area.
10. Before starting to drive truck:
  - a. Be in operating position.
  - b. Be sure parking brake is engaged.
  - c. Put direction control in neutral.
  - d. Start engine.
  - e. Check functioning of direction and speed controls, steering, brakes, warning devices, and any load handling attachments.
11. Before leaving truck
  - a. Stop truck.
  - b. Put directional control in neutral.
  - c. Apply the parking brake.
  - d. Stop the engine by turning off the ignition circuit.
  - e. Put blocks at the wheels if truck is on an incline.
12. Brakes, steering mechanisms, control mechanisms, warning devices, lights, governors, guards, safety devices, and frame members must be carefully and regularly inspected and maintained in a safe operating condition.
13. Special trucks or devices designed and approved for hazardous area operation must receive special attention to ensure that maintenance preserves the original, approved, safe-operating features.
14. Fuel systems must be checked for leaks and condition of parts. Extra special consideration must be given in the case of a leak in the fuel system. Action must be taken to prevent the use of the truck until the leak has been corrected.
15. The truck manufacturer's capacity, operation, and maintenance instruction plates, tags, or decals must be maintained in legible condition.
16. Batteries, motors, controllers, limit switches, protective devices, electrical conductors, and connections must be inspected and maintained in conformance with good practice. Special attention must be paid to the condition of electrical insulation.
17. To avoid injury to personnel or damage to the equipment, consult the manufacturer's procedures in replacing contacts on any battery connection.
18. Industrial trucks must be kept in a clean condition to minimize fire hazards and help in the detection of loose or defective parts.
19. Modifications and additions that affect capacity and safe truck operation must not be done without the manufacturer's prior written approval. Capacity, operation and maintenance instruction plates, tags, or decals must be changed accordingly. This is an OSHA requirement.
20. Care must be taken to assure that all replacement parts, including tires, are interchangeable with the original parts and of a quality at least equal to that provided in the original equipment. Parts, including tires, are to be installed per the manufacturer's procedures. Always use genuine CLARK or CLARK-approved parts.
21. Use special care when removing heavy components from the truck, such as counterweight, seat deck, upright, etc. Be sure that lifting and handling equipment is of the correct capacity and in good condition. Also, this removal may upset the stability of the truck. The frame must always be safely blocked for major component removal.

**NOTE**

**You should also be familiar with additional operating and maintenance safety instructions contained in the following publications:**

ANSI / ITSDF B56.1 : Operator Control-Industrial Tow Tractors (Safety Standard For Powered Industrial Trucks).

NFPA 505: Fire Safety Standard for Powered Industrial Trucks: Type Designations, Areas of Use, Maintenance and Operation. Available from: National Fire Protection Assoc., Inc., Batterymarch Park, Quincy, MA 02269.

General Industrial Standards, OSHA 2206: OSHA Safety and Health Standards (29 CFR 1910), Subpart N-Materials Handling and Storage, Section 1910.178 Powered Industrial Trucks. For sale by: Superintendent of Documents, U.S. Government Printing Office, Washington, DC 20402.

## Section 2

### Lifting, Jacking, and Blocking the Truck

**WARNING**

Lifting or jacking any large piece of equipment such as your fork truck presents obvious hazards. It must be done with great care and forethought. Consult the truck weight tabulations in Group 40, "Specifications" to ensure that your lifting equipment is of adequate capacity.

### Safe Parking

Before working on truck:

1. Park truck on a hard, level, and solid surface, such as a concrete floor with no gaps or breaks.
2. Put upright in vertical position and fully lower the forks or attachment.
3. Put all controls in neutral. Turn key switch OFF and remove key.
4. Apply the parking brake and block the wheels.

#### WARNING

**Defective equipment can cause accidents. All tools and lifting equipment must be in good condition, meet the load capacity requirements and have OSHA labels when required. Tools with defects can have failures causing severe injury or death.**

### Lifting, Blocking, and Jacking Points

Use the following illustration to locate general lifting, blocking, and jacking points on the truck. Read the procedures for raising, blocking, or jacking specific components of the truck to make sure you understand the correct, safe procedures

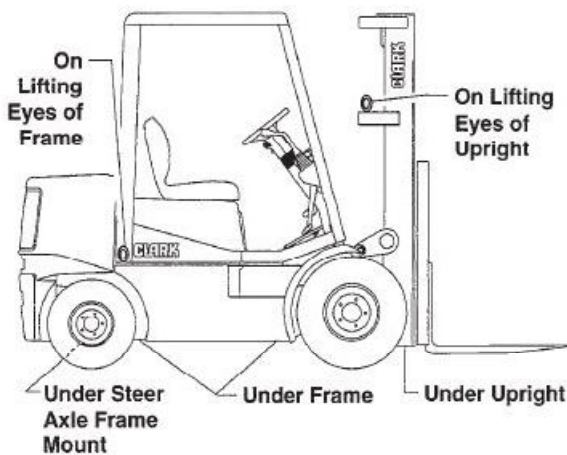

#### WARNING

**Do not attempt to lift the truck by the overhead guard or the counterweight. Severe injury may result and the truck can be damaged.**

### Raising Drive Wheels Off Floor

This procedure uses the upright as a lever to lift the drive wheels off the floor and prevent accidents due to inadvertent powering of the drive wheels.

1. Park truck safely as described in “Safe Parking.” Block steer wheels.
2. Be sure upright trunnion bolts are tight. Bolt torques must be 75-80 N·m (55-59 ft-lb).
3. Start the engine. Tilt the upright fully back. Adjust upright height as necessary to put blocking underneath the lower end of the upright.
4. Put a solid 100 x 100 mm (4 x 4 in) hardwood block under the front section of each upright rail. Put a 3-6 mm (.125-.250 in) steel plate on top of each block.

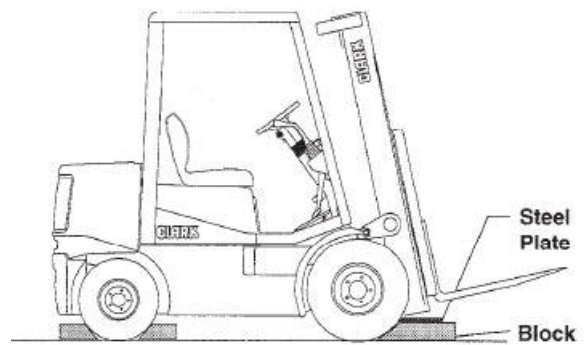

5. Tilt upright fully forward. This raises the drive wheels off the floor. Release the tilt control lever and turn engine OFF.

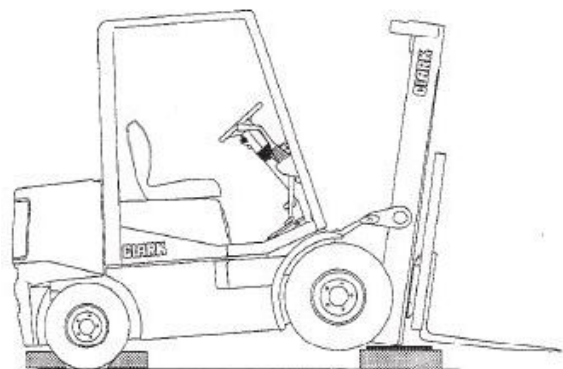

6. Insert blocking under the frame behind the drive wheels or slip wheel cradles under the drive wheels. If using blocking, check for safe clearance between drive wheels and floor and blocks.

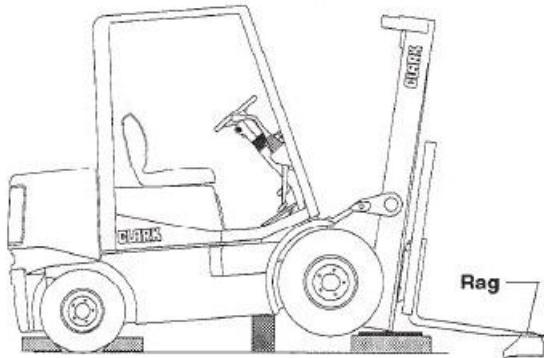

### NOTE

When forks are raised as in illustration above, use shop rags, paper, or bright tape on fork tips to signal the danger of tripping.

7. Check for stable condition of the truck. Be sure that the blocks are located securely under the truck frame before operating the drive or working on truck.
8. Lower the drive wheels to the floor and remove the blocks by reversing the above procedure.

## Raising Truck with A Hoist

When suitable equipment is available, the front of the truck may be raised by means of a hoist, with wheel cradles placed under the wheels or blocking placed under the frame.



### CAUTION

When lifting the front of the truck watch truck for signs of lateral instability. It may tip sideways. You may have to support or guide the side of the truck or overhead guard to prevent tipping.

1. Park truck safely as described in "Safe Parking." Block rear steer wheels.
2. Check upright mounts, mounting pins, and pin retainers to ensure they are in good condition.

3. To raise the front of the truck using the upright, spread two chains on the outer rail tiebar of the upright.

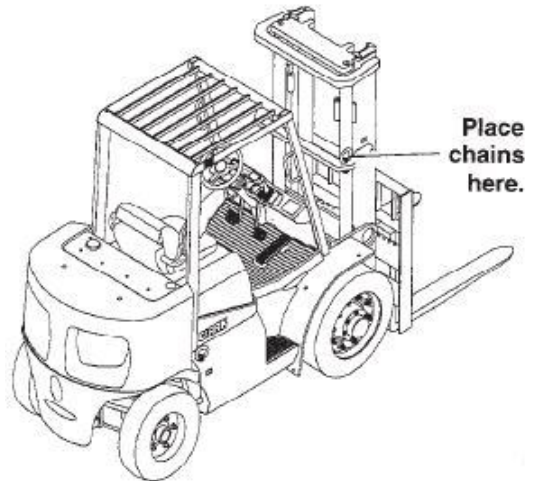

### WARNING

Chain and hoist used to lift truck should be checked to make sure they are of safe lifting capacity. See the truck data plate for information.

4. Slowly lift truck and lower drive wheels onto the cradles or place blocking under frame prop points.

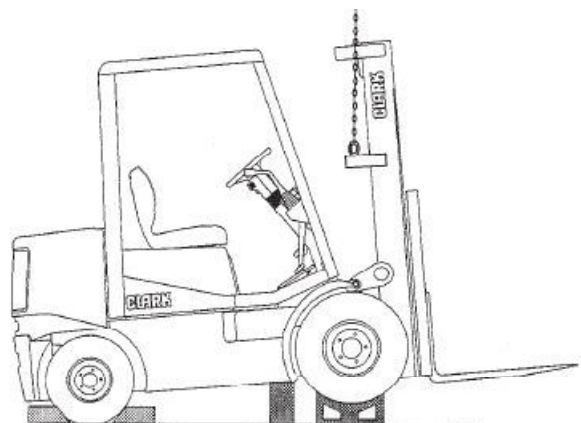

5. When maintenance work is completed, lower the truck to the floor by reversing the lifting procedure. Check to be sure no tools or equipment are under the truck or wheels.

### Blocking the Upright In Raised Position

This procedure is used to safely provide clearance for access from the front of truck to components on or near the drive axle. Illustrations show upright with forks removed however, fork removal is not necessary

1. Park truck safely as described in "Safe Parking."
2. Put blocks in front of and behind drive wheels.
3. Put wooden support blocks conveniently near upright rails before raising the upright. Use two 100 x 100 mm (4 x 4 in) hardwood blocks or equal, of about 300 x 300 mm (12 in) and 600 x 600 mm (24 in) length.

**NOTE**

**For standard uprights, block may need length cut to suit. For triple stage uprights, the carriage may be blocked up, as shown.**

4. Start engine and raise the upright carriage.
5. Hold the taller block against inner rail and lower the upright until carriage rests on block.

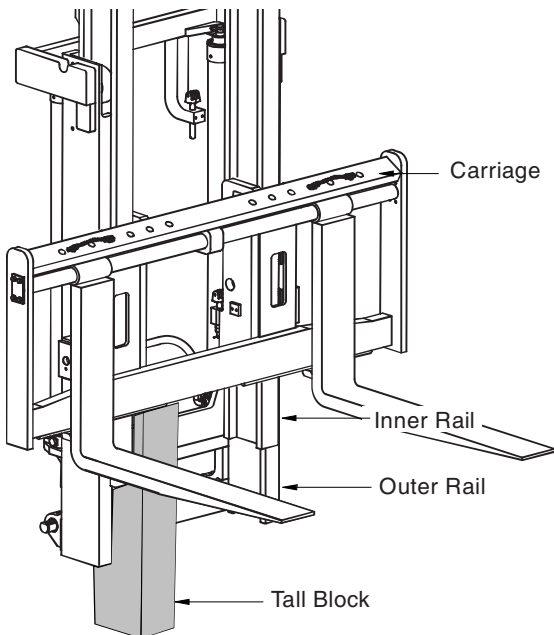

6. Hold the shorter block against the outer rail and lower the upright until inner rail rests on the block.

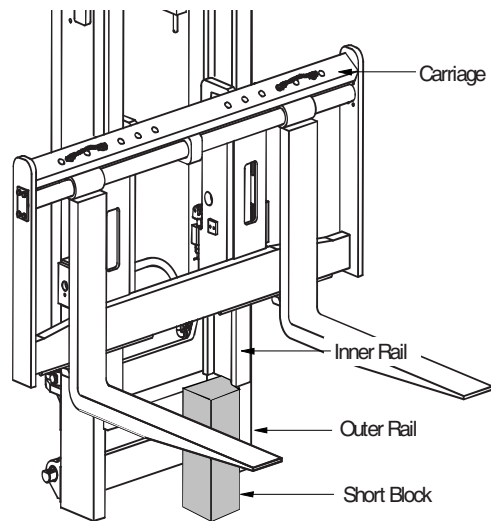

7. Reverse the procedure to remove blocking.

### Raising Rear of Truck

The truck may be raised at the rear by jacking and blocking under the center of the frame member at either the front or rear steer axle mounting, or under the center section of the steer axle.

Refer to truck data plate for truck weights.

**WARNING**

**An incorrectly installed counterweight can move or fall unexpectedly. Never lift or block a truck using the counterweight. Failure to follow procedures outlined in this manual can result in injury or death.**

1. Park truck safely as described in "Safe Parking." Put blocks at front and rear of drive wheels.

- Put the jack under side frame near the center of the truck.

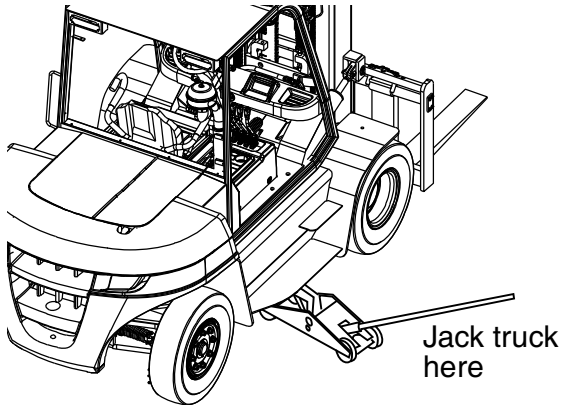

### IMPORTANT

Be sure to put the jack squarely and fully under the main side structure of the frame. Do not put the jack under the outer covers which enclose the fuel and hydraulic sump tanks.

- Carefully raise the truck one side at a time, only as high as necessary to do the maintenance work and not more than a maximum of 150 mm (6 in) total.
- Put blocks under the side frame, at each side of the jack. Spread the blocks close to the steer and drive wheels for maximum stability.

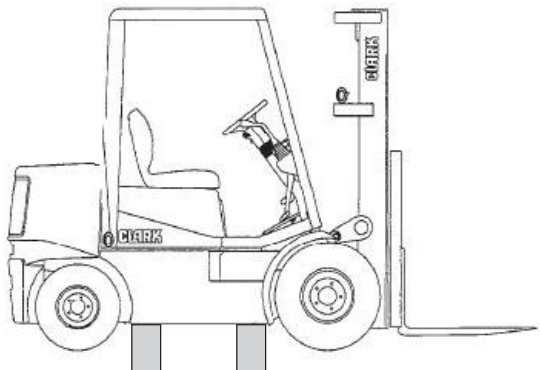

- If using one jack, lower the truck onto the blocks and move the jack to the opposite side. Repeat the lifting procedure.
- Put the same size blocks under each side of the truck so it will be level.



### CAUTION

Before performing any maintenance work, check the truck for stable condition on the blocking.

- When maintenance work is completed, lower the entire truck to the floor by reversing the lifting procedure. Lower the truck one side at a time, while carefully removing the blocks. Check to be sure no tools or equipment are under the truck or wheels.

### NOTE

Depending on jack height, shims under the tires may be needed for clearance to allow removal of jack.

## Shipping Tie-Down Instructions

- Front of Truck
  - With Upright and Carriage Installed
    - Lower the carriage fully.
    - Put a tie down (e.g., chain) between the carriage fork bars.

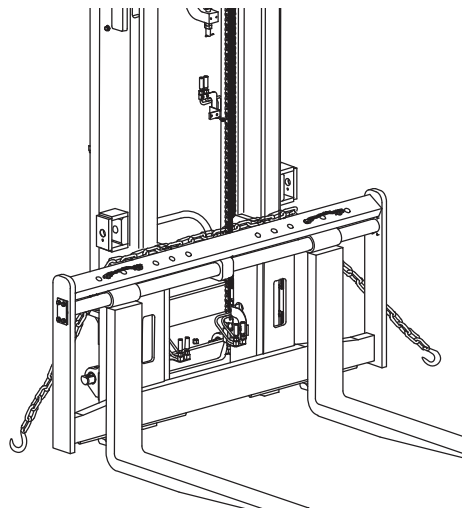

- Without an Upright and Carriage Installed
    - Put a chain across the truck floor plate. Protect truck from chain damage by using covered chain or protective material under the chain at contact points.
- Rear of Truck
    - Attach the tie down to pocket in bottom of counterweight.