

SERVICE MANUAL

C20/25/30/35 D/L/G
C20/25/30/32C L

Rated Capacity : 2000 - 3500 kg

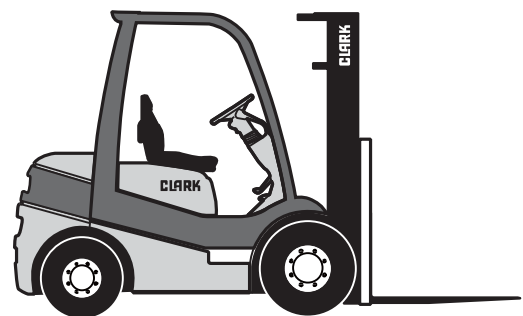

Part No. 8121700
Book No. SM 996 (Rev 1.4)
Aug. 2018



CLARK MATERIAL HANDLING INTERNATIONAL
215, Ojeong-ro, Bucheon-Si, Gyeonggi-do, Korea
Tel: 82-32-680-6300 [www.clarkmhc.co.kr]

COPYRIGHT WARNING!
Do not sell or distribute, information for CLARK dealers only.

GROUP INDEX

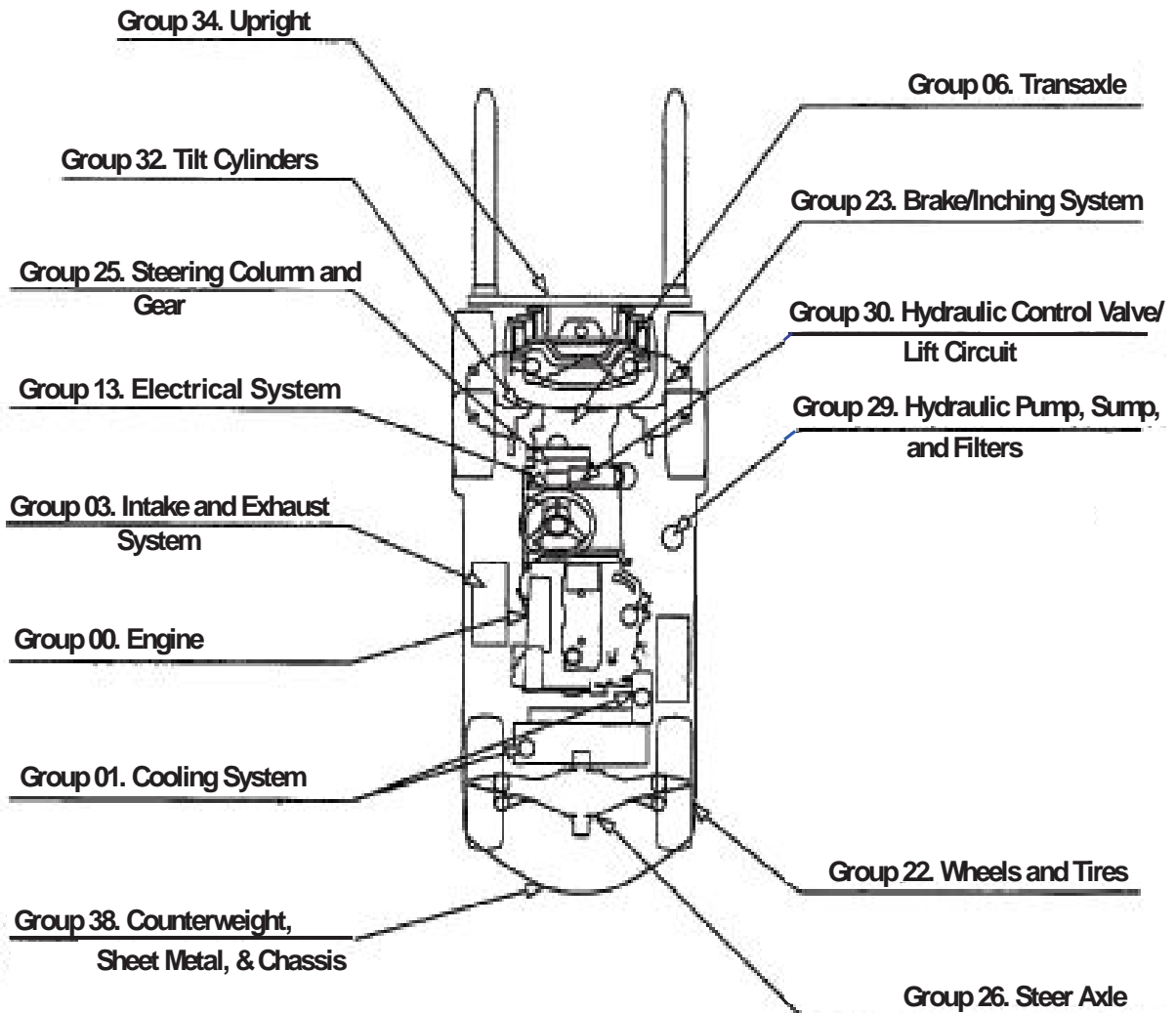

Safe Parking

Before working on truck:

1. Park truck on a hard, level, and solid surface, such as a concrete floor with no gaps or breaks.
2. Put upright in vertical position and fully lower the forks or attachment.
3. Put all controls in neutral. Turn key switch OFF and remove key.
4. Apply the parking brake and block the wheels.



WARNING

Defective equipment can cause accidents. All tools and lifting equipment must be in good condition, meet the load capacity requirements and have OSHA labels when required. Tools with defects can have failures causing severe injury or death.

Lifting, Blocking, and Jacking Points

Use the following illustration to locate general lifting, blocking, and jacking points on the truck. Read the procedures for raising, blocking, or jacking specific components of the truck to make sure you understand the correct, safe procedures

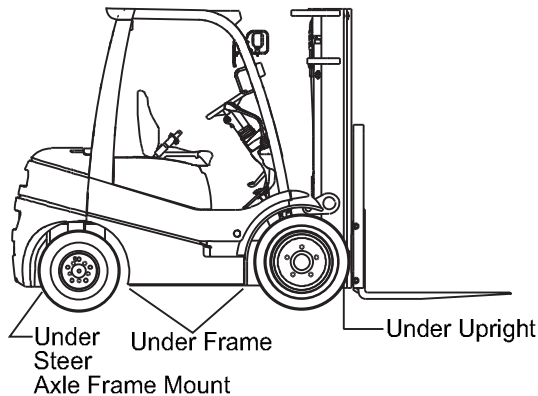

WARNING

Do not attempt to lift the truck by the overhead guard or the counterweight. Severe injury may result and the truck can be damaged.

Raising Drive Wheels Off Floor

This procedure uses the upright as a lever to lift the drive wheels off the floor and prevent accidents due to inadvertent powering of the drive wheels.

1. Park truck safely as described in "Safe Parking." Block steer wheels.
2. Be sure upright trunnion bolts are tight. Bolt torques must be 75-80 N·m (55-59 ft-lb).
3. Start the engine. Tilt the upright fully back. Adjust upright height as necessary to put blocking underneath the lower end of the upright.
4. Put a solid 100 x 100 mm (4 x 4 in) hardwood block under the front section of each upright rail. Put a 3-6 mm (.125-.250 in) steel plate on top of each block.

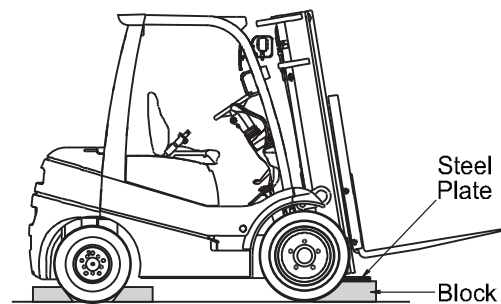

5. Tilt upright fully forward. This raises the drive wheels off the floor. Release the tilt control lever and turn engine OFF.

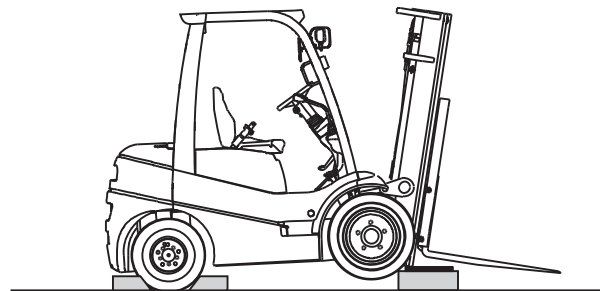

6. Insert blocking under the frame behind the drive wheels or slip wheel cradles under the drive wheels. If using blocking, check for safe clearance between drive wheels and floor and blocks.

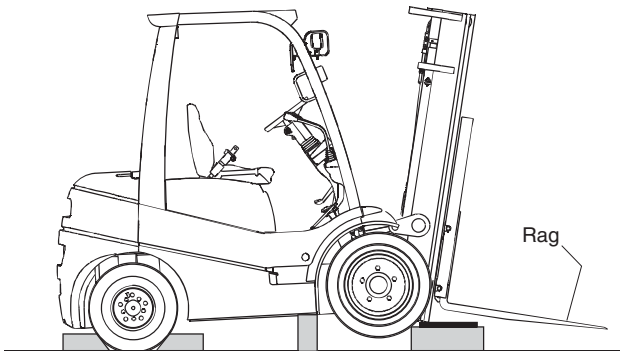

NOTE

When forks are raised as in illustration above, use shop rags, paper, or bright tape on fork tips to signal the danger of tripping.

7. Check for stable condition of the truck. Be sure that the blocks are located securely under the truck frame before operating the drive or working on truck.
8. Lower the drive wheels to the floor and remove the blocks by reversing the above procedure.

Raising Truck with A Hoist

When suitable equipment is available, the front of the truck may be raised by means of a hoist, with wheel cradles placed under the wheels or blocking placed under the frame.



CAUTION

When lifting the front of the truck watch truck for signs of lateral instability. It may tip sideways. You may have to support or guide the side of the truck or overhead guard to prevent tipping.

1. Park truck safely as described in "Safe Parking." Block rear steer wheels.
2. Check trunnion bolts to make sure they are tightened to correct torque. Bolt torques must be 75-80 N·m (55-59 ft-lb).

3. To raise the front of the truck using the upright, spread two chains on the outer rail tiebar of the upright.

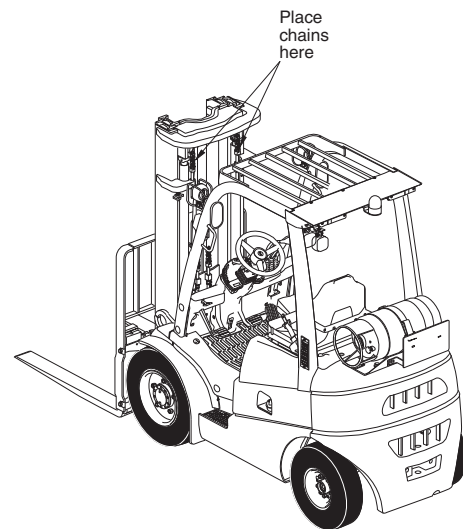

WARNING

Chain and hoist used to lift truck should be checked to make sure they are of safe lifting capacity. See the truck data plate for information.

4. Slowly lift truck and lower drive wheels onto the cradles or place blocking under frame prop points.

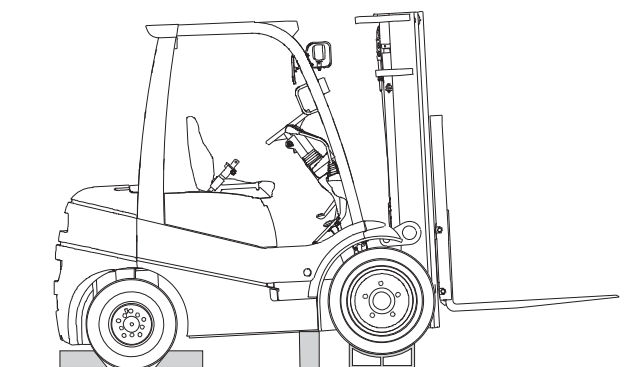

5. When maintenance work is completed, lower the truck to the floor by reversing the lifting procedure. Check to be sure no tools or equipment are under the truck or wheels.

Blocking the Upright In Raised Position

This procedure is used to safely provide clearance for access from the front of truck to components on or near the drive axle. Illustrations show upright with forks removed however, fork removal is not necessary

1. Park truck safely as described in "Safe Parking."
2. Put blocks in front of and behind drive wheels.
3. Put wooden support blocks conveniently near upright rails before raising the upright. Use two 100 x 100 mm (4 x 4 in) hardwood blocks or equal, of about 300 x 300 mm (12 in) and 600 x 600 mm (24 in) length.

NOTE

For standard uprights, block may need length cut to suit. For triple stage uprights, the carriage may be blocked up, as shown.

4. Start engine and raise the upright carriage.
5. Hold the taller block against inner rail and lower the upright until carriage rests on block.

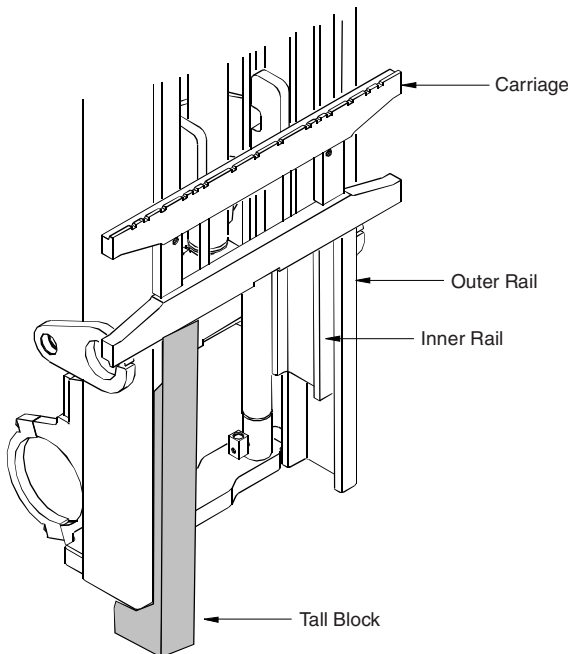

6. Hold the shorter block against the outer rail and lower the upright until inner rail rests on the block.

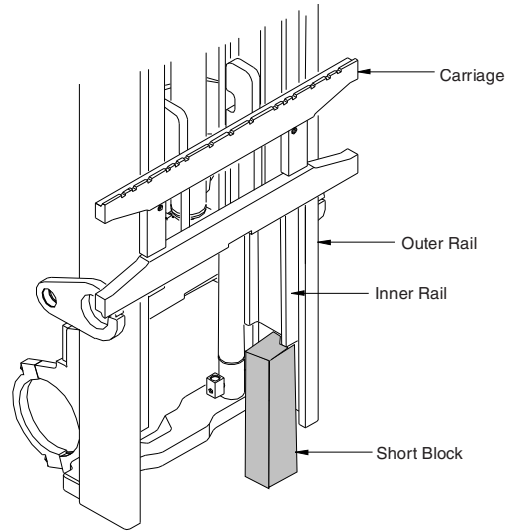

7. Reverse the procedure to remove blocking.

Raising Rear of Truck

The truck may be raised at the rear by jacking and blocking under the center of the frame member at either the front or rear steer axle mounting, or under the center section of the steer axle.

Refer to truck data plate for truck weights.

WARNING

An incorrectly installed counterweight can move or fall unexpectedly. Never lift or block a truck using the counterweight. Failure to follow procedures outlined in this manual can result in injury or death.

1. Park truck safely as described in "Safe Parking." Put blocks at front and rear of drive wheels.

- Put a floor jack under the steer axle mounting frame member, centered between the two wheels.

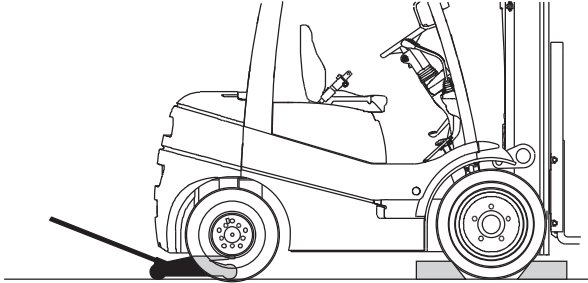

WARNING

Never lift the truck by the counterweight.

NOTE

If there is insufficient clearance under frame for your jack, the truck may first be driven onto shims, such as 25 x 150 x 300 mm (1 x 6 x 12 in) pieces of board, to increase the truck frame underclearance.

- Raise the truck only as high as necessary to perform the maintenance work.
- Put blocks at both sides of the truck, fully under the frame main side structure. Put the blocks in front of but close to the counterweight and steer wheels for best truck stability.

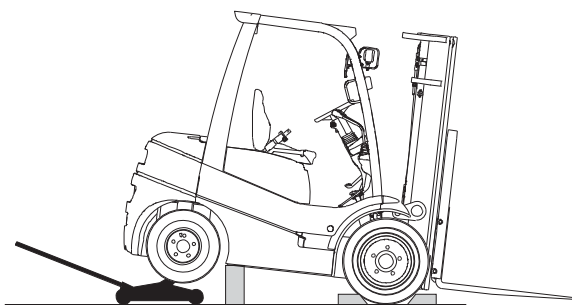

Put an equal amount of blocks under each side of the truck to provide a level working position.

- Lower the truck onto the blocks and remove the jack.

CAUTION

Before performing any maintenance work, check the truck for stable condition on the blocking.

- When maintenance work is completed, lower the rear of truck to the floor by reversing the above procedure and lowering each side of the truck 50 mm (2 in) at a time:
 - Put jack under frame and raise truck.
 - Carefully remove blocks and lower truck.
 - Remove jack and blocks from drive wheels.

Raising Entire Truck

Refer to truck data plate for truck weights.

- Park truck safely as described in “Safe Parking.” Lower upright fully.
- If necessary, drive truck onto boards to increase underclearance.

WARNING

SIDE-TO-SIDE TIPOVER. When jacking side of truck, be sure upright is lowered fully and do not raise one side of the truck more than about 50 mm (2 in) higher than the other, to avoid tipping truck over laterally.

END-TO-END TIPOVER. If the upright and transaxle are removed while the truck is blocked up, the truck will tip backwards due to the heavy counterweight. Both upright and counterweight must be removed before attempting to raise the truck for transaxle removal. The back of the truck must be supported by blocking under the steer axle to prevent movement.

The reverse is also true. If the counterweight is removed while the truck is up on blocks, the weight of the upright and transaxle will cause the truck to tip on the front blocks and fall forward.

- Put the jack under side frame near the center of the truck.

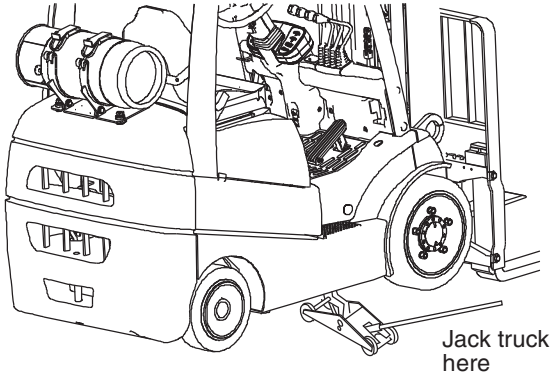

IMPORTANT

Be sure to put the jack squarely and fully under the main side structure of the frame. Do not put the jack under the outer covers which enclose the fuel and hydraulic sump tanks.

- Carefully raise the truck one side at a time, only as high as necessary to do the maintenance work and not more than a maximum of 150 mm (6 in) total.
- Put blocks under the side frame, at each side of the jack. Spread the blocks close to the steer and drive wheels for maximum stability.

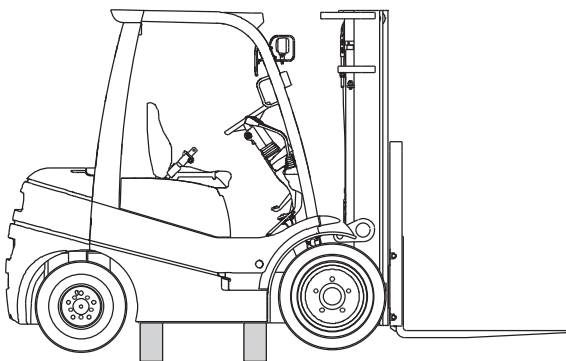

- If using one jack, lower the truck onto the blocks and move the jack to the opposite side. Repeat the lifting procedure.
- Put the same size blocks under each side of the truck so it will be level.



CAUTION

Before performing any maintenance work, check the truck for stable condition on the blocking.

- When maintenance work is completed, lower the entire truck to the floor by reversing the lifting procedure. Lower the truck one side at a time, while carefully removing the blocks. Check to be sure no tools or equipment are under the truck or wheels.

NOTE

Depending on jack height, shims under the tires may be needed for clearance to allow removal of jack.

Shipping Tie-Down Instructions

- Front of Truck
 - With Upright and Carriage Installed
 - Lower the carriage fully.
 - Put a tie down (e.g., chain) between the carriage fork bars.

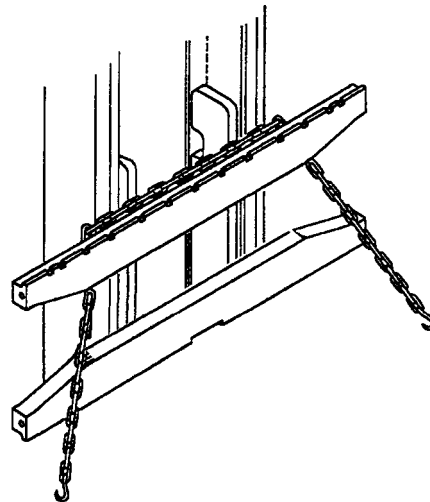

- Without an Upright and Carriage Installed
 - Put a chain across the truck floor plate. Protect truck from chain damage by using covered chain or protective material under the chain at contact points.
- Rear of Truck
 - Attach the tie down to pocket in bottom of counterweight.

Section 3

Towing

If your truck is disabled but can be moved freely on its own wheels without further damage, use the following procedures to tow the truck safely to a repair area.

WARNING

It is important for your safety and to the care of your lift truck to use the proper equipment and carefully follow these recommendations for safe towing.

Do not tow a lift truck if there is a problem with the brakes or tires, or if the steering cannot be operated.

Do not tow the disabled truck up or down ramps or steep inclines.

Do not attempt to tow the disabled truck if traction or weather conditions are poor.

1. Be sure to apply the parking brake or block the drive wheels on the disabled truck while working around it.
2. When possible, raise the carriage (forks) on the disabled truck 300 mm (12 in) from the floor or ground. Secure the carriage on the upright with a chain.
3. Use a truck for towing that is of equal or larger capacity than the disabled truck. Carry a partial load on the tow truck for improved traction.
4. Check that the counterweight bolts on both trucks are in place and properly torqued to 440-490 N·m (325-361 ft-lb). These bolts are made of special, high-tensile steel and are not commercially available. When necessary, replace these bolts only with a genuine CLARK replacement part.
5. Use an approved, solid metal tow bar with towing couplers that connect to the towing pins in the counterweights.

NOTE

DOT-approved towing equipment is available from your CLARK dealer.

6. Release the parking brake on the towed vehicle. Place directional control lever in neutral.
7. Tow the disabled truck backwards. An operator must be on the disabled truck.

CAUTION

The power steering will not operate on the disabled truck when the engine is not running. The steering handwheel will be difficult to turn.

8. Tow the truck slowly. Careful towing is necessary to prevent injury to personnel or damage to the disabled truck. The truck should be towed at a speed of less than 8 kph (5 mph, or a moderate walking speed) with a driver in place and steering the disabled truck.

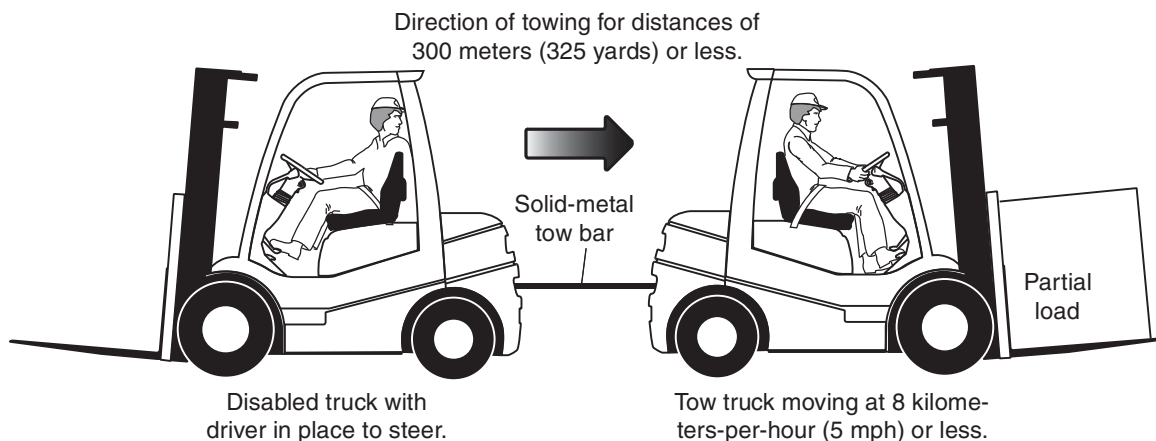

IMPORTANT

Do not lift the disabled truck or any wheels off the floor while the truck is being towed.

9. Park the disabled truck in authorized areas only. Fully lower the forks on the floor, leave the directional control in neutral, turn the ignition switch to OFF, and engage the parking brake. Remove the ignition key and, when necessary, block the wheels to prevent the truck from rolling.

**WARNING**

Always engage the parking brake when parking a lift truck. The truck can roll and cause injury or death to personnel near it.

LIFT TRUCK PARKING

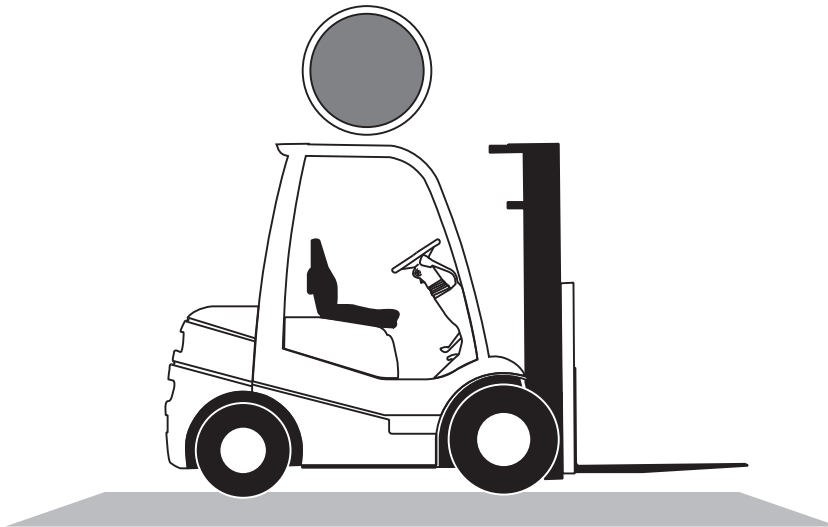

Section 1

Maintenance Schedules

“Periodic Service” and “Planned Maintenance”

The term “periodic service” includes all maintenance tasks that should be performed on a regularly scheduled basis.

The term “Planned Maintenance” indicates a formalized program of basic inspections, adjustments, and lubrications that the CLARK service organization provides customers at a prescribed interval, usually 500 hours. The recommended basic “Planned Maintenance” procedure is given in Section 2 of this Group.

The current Section, “Maintenance Schedules,” specifies all maintenance tasks—including Planned Maintenance tasks—that should be performed periodically, and suggests intervals at which they should be performed.

Determining Maintenance Intervals

Time intervals on the charts on the next four pages and elsewhere in this manual relate to truck operating hours as recorded on the hourmeter, and are based on experience CLARK has found to be convenient and suitable under normal operation. Standard operating condition classifications are:

Normal Operation:

- Eight-hour material handling, mostly in buildings or in clean, open air on clean, paved surfaces.

Severe Operation:

- Prolonged operating hours or constant usage.

Extreme Operation:

- In sandy or dusty locations, such as cement plants, lumber mills, and coal dust or stone crushing sites.
- High-temperature locations, such as steel mills and foundries.
- Sudden temperature changes, such as constant trips from buildings into the open air, or in refrigeration plants.

IMPORTANT

MAINTENANCE INTERVALS. If the lift truck is used in severe or extreme operating conditions, the maintenance intervals should be shortened accordingly.

Since the operating environments of lift trucks vary widely, the above descriptions are highly generalized and should be applied as actual conditions dictate.